



# Manual

for

## Omme Lift Type

**1750 R / 1900 RJ**

**1950 R / 2100 RJ**

**2200 R / 2350 RJ**

**2600 R / 2750 RJ**

**3000 R / 3150 RJ**

### **OMME LIFT A/S**

Lægårdsvej 4, DK-7260 Sønder Omme  
Tel. +45 75341300 Fax +45 75341592  
[www.ommelift.dk](http://www.ommelift.dk)



# EU-Conformity Certificate

Name of manufacturer or appointed attorney in the community:

**OMME LIFT A/S**

Address of the manufacturer:

**Lægårdsvej 4  
DK-7260 Sønder Omme**

We declare, that the product,

Description of the machine:

<b>Type of product</b>	Hoist
<b>Description of machine</b>	Aerial lift with telescopic function mounted on crawler chassis
<b>Type of machine</b>	1750 R
<b>Serial number</b> xxxx PLL	<b>Construction year</b> 2xxx

which we have put on the market, with regard to conception and construction, corresponds to the essential requirements concerning safety and health in the EU-direction/s mentioned below:

EU-Machine Directive 2006/42/EC  
EMC Directive 2004/108/EC

Documented from Danish Technological Institute  
Notified Body ID no.: 0396

**EC type-examination no.: TI-10-MD-0320**  
For this the EU-standards mentioned below were used:  
DS/EN 280 + A2 / EN 60204

**Signature**

Director  
**Designation of occupation**

Sdr.Omme  
**Place**

xx.xx.2xxx  
**Date**

**Remarks:**

This certificate complies with the manufacturer certificate as prescribed in the EU-machine directive 2006/42/EC. If there are any changes on the product, mentioned above, this certificate is invalid.

# EU-Conformity Certificate

Name of manufacturer or appointed attorney in the community:

**OMME LIFT A/S**

Address of the manufacturer:

**Lægårdsvej 4  
DK-7260 Sønder Omme**

We declare, that the product,

Description of the machine:

<b>Type of product</b>	Hoist
<b>Description of machine</b>	Aerial lift with telescopic function mounted on crawler chassis
<b>Type of machine</b>	1900 RJ
<b>Serial number</b> xxxx PLL	<b>Construction year</b> 2xxx

which we have put on the market, with regard to conception and construction, corresponds to the essential requirements concerning safety and health in the EU-direction/s mentioned below:

EU-Machine Directive  2006/42/EC  
EMC Directive 2004/108/EC

Documented from Danish Technological Institute  
Notified Body ID no.: 0396

**EC type-examination no.: TI-10-MD-0320**  
For this the EU-standards mentioned below were used:  
DS/EN 280 + A2 / EN 60204

**Signature**

Director  
**Designation of occupation**

Sdr.Omme  
**Place**

xx.xx.2xxx  
**Date**

**Remarks:**

This certificate complies with the manufacturer certificate as prescribed in the EU-machine directive 2006/42/EC. If there are any changes on the product, mentioned above, this certificate is invalid.

# EU-Conformity Certificate

Name of manufacturer or appointed attorney in the community:

**OMME LIFT A/S**

Address of the manufacturer:

**Lægårdsvej 4  
DK-7260 Sønder Omme**

We declare, that the product,

Description of the machine:

<b>Type of product</b>	Hoist
<b>Description of machine</b>	Aerial lift with telescopic function mounted on crawler chassis
<b>Type of machine</b>	1950 R
<b>Serial number</b> xxxx ULL	<b>Construction year</b> 2xxx

which we have put on the market, with regard to conception and construction, corresponds to the essential requirements concerning safety and health in the EU-direction/s mentioned below:

EU-Machine Directive  2006/42/EC  
EMC Directive 2004/108/EC

Documented from Danish Technological Institute  
Notified Body ID no.: 0396

**EC type-examination no.: TI-10-MD-0322**  
For this the EU-standards mentioned below were used:  
DS/EN 280 + A2 / EN 60204

**Signature**

Director  
**Designation of occupation**

Sdr.Omme  
**Place**

xx.xx.2xxx  
**Date**

**Remarks:**

This certificate complies with the manufacturer certificate as prescribed in the EU-machine directive 2006/42/EC. If there are any changes on the product, mentioned above, this certificate is invalid.

# EU-Conformity Certificate

Name of manufacturer or appointed attorney in the community:

**OMME LIFT A/S**

Address of the manufacturer:

**Lægårdsvej 4  
DK-7260 Sønder Omme**

We declare, that the product,

Description of the machine:

<b>Type of product</b>	Hoist
<b>Description of machine</b>	Aerial lift with telescopic function mounted on crawler chassis
<b>Type of machine</b>	2100 RJ
<b>Serial number</b> xxxx ULL	<b>Construction year</b> 2xxx

which we have put on the market, with regard to conception and construction, corresponds to the essential requirements concerning safety and health in the EU-direction/s mentioned below:

EU-Machine Directive 2006/42/EC  
EMC Directive 2004/108/EC

Documented from Danish Technological Institute  
Notified Body ID no.: 0396

**EC type-examination no.: TI-10-MD-0322**  
For this the EU-standards mentioned below were used:  
DS/EN 280 + A2 / EN 60204

**Signature**

Director  
**Designation of occupation**

Sdr.Omme  
**Place**

xx.xx.2xxx  
**Date**

**Remarks:**

This certificate complies with the manufacturer certificate as prescribed in the EU-machine directive 2006/42/EC. If there are any changes on the product, mentioned above, this certificate is invalid.

# EU-Conformity Certificate

Name of manufacturer or appointed attorney in the community:

**OMME LIFT A/S**

Address of the manufacturer:

**Lægårdsvej 4  
DK-7260 Sønder Omme**

We declare, that the product,

Description of the machine:

<b>Type of product</b>	Hoist
<b>Description of machine</b>	Aerial lift with telescopic function mounted on crawler chassis
<b>Type of machine</b>	2200 R
<b>Serial number</b> xxxx SLL	<b>Construction year</b> 2xxx

which we have put on the market, with regard to conception and construction, corresponds to the essential requirements concerning safety and health in the EU-direction/s mentioned below:

EU-Machine Directive    2006/42/EC  
EMC Directive 2004/108/EC

Documented from Danish Technological Institute  
Notified Body ID no.: 0396

**EC type-examination no.: TI-10-MD-0323**  
For this the EU-standards mentioned below were used:  
DS/EN 280 + A2 / EN 60204

**Signature**

Sdr. Omme  
**Place**

Director  
**Designation of occupation**

xx.xx.2xxx  
**Date**

**Remarks:**

This certificate complies with the manufacturer certificate as prescribed in the EU-machine directive 2006/42/EC. If there are any changes on the product, mentioned above, this certificate is invalid.

# EU-Conformity Certificate

Name of manufacturer or appointed attorney in the community:

**OMME LIFT A/S**

Address of the manufacturer:

**Lægårdsvej 4  
DK-7260 Sønder Omme**

We declare, that the product,

Description of the machine:

<b>Type of product</b>	Hoist
<b>Description of machine</b>	Aerial lift with telescopic function mounted on crawler chassis
<b>Type of machine</b>	2350 RJ
<b>Serial number</b> xxxx SLL	<b>Construction year</b> 2xxx

which we have put on the market, with regard to conception and construction, corresponds to the essential requirements concerning safety and health in the EU-direction/s mentioned below:

EU-Machine Directive 2006/42/EC  
EMC Directive 2004/108/EC

Documented from Danish Technological Institute  
Notified Body ID no.: 0396

**EC type-examination no.: TI-10-MD-0323**  
For this the EU-standards mentioned below were used:  
DS/EN 280 + A2 / EN 60204

**Signature**

Sdr.Omme  
**Place**

Director  
**Designation of occupation**

xx.xx.2xxx  
**Date**

**Remarks:**

This certificate complies with the manufacturer certificate as prescribed in the EU-machine directive 2006/42/EC. If there are any changes on the product, mentioned above, this certificate is invalid.



# EU-Conformity Certificate

Name of manufacturer or appointed attorney in the community:

**OMME LIFT A/S**

Address of the manufacturer:

**Lægårdsvej 4  
DK-7260 Sønder Omme**

We declare, that the product,

Description of the machine:

<b>Type of product</b>	Hoist
<b>Description of machine</b>	Aerial lift with telescopic function mounted on crawler chassis
<b>Type of machine</b>	2600 R
<b>Serial number</b> xxxx TLL	<b>Construction year</b> 2xxx

which we have put on the market, with regard to conception and construction, corresponds to the essential requirements concerning safety and health in the EU-direction/s mentioned below:

EU-Machine Directive  2006/42/EC  
EMC Directive 2004/108/EC

Documented from Danish Technological Institute  
Notified Body ID no.: 0396

**EC type-examination no.: TI-10-MD-0324**  
For this the EU-standards mentioned below were used:  
DS/EN 280 + A2 / EN 60204

**Signature**

**Director  
Designation of occupation**

**Sdr.Omme  
Place**

**xx.xx.2xxx  
Date**

**Remarks:**

This certificate complies with the manufacturer certificate as prescribed in the EU-machine directive 2006/42/EC. If there are any changes on the product, mentioned above, this certificate is invalid.

# EU-Conformity Certificate

Name of manufacturer or appointed attorney in the community:

**OMME LIFT A/S**

Address of the manufacturer:

**Lægårdsvej 4  
DK-7260 Sønder Omme**

We declare, that the product,

Description of the machine:

<b>Type of product</b>	Hoist
<b>Description of machine</b>	Aerial lift with telescopic function mounted on crawler chassis
<b>Type of machine</b>	2750 RJ
<b>Serial number</b> xxxx TLL	<b>Construction year</b> 2xxx

which we have put on the market, with regard to conception and construction, corresponds to the essential requirements concerning safety and health in the EU-direction/s mentioned below:

EU-Machine Directive  2006/42/EC  
EMC Directive 2004/108/EC

Documented from Danish Technological Institute  
Notified Body ID no.: 0396

**EC type-examination no.: TI-10-MD-0324**  
For this the EU-standards mentioned below were used:  
DS/EN 280 + A2 / EN 60204

**Signature**

Sdr.Omme  
**Place**

Director  
**Designation of occupation**

xx.xx.2xxx  
**Date**

**Remarks:**

This certificate complies with the manufacturer certificate as prescribed in the EU-machine directive 2006/42/EC. If there are any changes on the product, mentioned above, this certificate is invalid.

# EU-Conformity Certificate

Name of manufacturer or appointed attorney in the community:

**OMME LIFT A/S**

Address of the manufacturer:

**Lægårdsvej 4  
DK-7260 Sønder Omme**

We declare, that the product,

Description of the machine:

<b>Type of product</b>	Hoist
<b>Description of machine</b>	Aerial lift with telescopic function mounted on crawler chassis
<b>Type of machine</b>	3000 R
<b>Serial number</b> xxxx VLL	<b>Construction year</b> 2xxx

which we have put on the market, with regard to conception and construction, corresponds to the essential requirements concerning safety and health in the EU-direction/s mentioned below:

EU-Machine Directive  2006/42/EC  
EMC Directive 2004/108/EC

Documented from Danish Technological Institute  
Notified Body ID no.: 0396

**EC type-examination no.: TI-10-MD-0326**

For this the EU-standards mentioned below were used:  
DS/EN 280 + A2 / EN 60204

<b>Signature</b>	<b>Director</b>
	<b>Designation of occupation</b>
Sdr.Omme	xx.xx.2xxx
<b>Place</b>	<b>Date</b>

**Remarks:**

This certificate complies with the manufacturer certificate as prescribed in the EU-machine directive 2006/42/EC.  
If there are any changes on the product, mentioned above, this certificate is invalid.

# EU-Conformity Certificate

Name of manufacturer or appointed attorney in the community:

**OMME LIFT A/S**

Address of the manufacturer:

**Lægårdsvej 4  
DK-7260 Sønder Omme**

We declare, that the product,

Description of the machine:

<b>Type of product</b>	Hoist
<b>Description of machine</b>	Aerial lift with telescopic function mounted on crawler chassis
<b>Type of machine</b>	3150 RJ
<b>Serial number</b> xxxx VLL	<b>Construction year</b> 2xxx

which we have put on the market, with regard to conception and construction, corresponds to the essential requirements concerning safety and health in the EU-direction/s mentioned below:

EU-Machine Directive 2006/42/EC  
EMC Directive 2004/108/EC

Documented from Danish Technological Institute  
Notified Body ID no.: 0396

**EC type-examination no.:** TI-10-MD-0326

For this the EU-standards mentioned below were used:  
DS/EN 280 + A2 / EN 60204

**Signature**

Sdr.Omme  
**Place**

Director  
**Designation of occupation**

xx.xx.2xxx  
**Date**

**Remarks:**

This certificate complies with the manufacturer certificate as prescribed in the EU-machine directive 2006/42/EC. If there are any changes on the product, mentioned above, this certificate is invalid.

## INTRODUCTION

We are pleased that you have chosen an OMME lift, and we are convinced that you will be pleased with it, too.

We have prepared this manual in order that you can make full use of all functions of the lift, and in order that you can use these with the highest degree of safety for both yourself and others. Consequently you should read this manual carefully before you start your lift.

The lift is designed corresponding to recognized standards.

It is important to follow our instructions for use and maintenance of the lift, moreover, you must make yourself familiar with the national regulations concerning the use of lifts, which also must be followed.

**Alterations and conversions which have not been carried out by OMME, just as non-professional adjustments of valves, shall exempt us from any liability for any consequential damage.**

If you have any questions concerning your OMME lift you will always be welcome to contact us.

OMME LIFT A/S



**Table of contents**

PREFACE

Introduction ..... - 1 -

Table of contents ..... - 2 -

Definition of the lift ..... - 4 -

Safety regulations ..... - 5 -

Description and field of application ..... - 6 -

Operation of the internal-combustion engine ..... - 10 -

STARTING OMME LIFT

1. Instructions ..... - 11 -

2. Emergency lowering ..... - 21 -

3. Manual control of stabilizers ..... - 25 -

HANDLING AND CONDUCT DURING OPERATION

1. Requirements to persons operating the lift ..... - 26 -

2. Permissible load/lateral force ..... - 26 -

3. Transport ..... - 26 -

3.a Lifting procedures ..... - 27 -

3.b Lifting points ..... - 28 -

3.c Lifting the lift ..... - 29 -

3.d Lifting beam ..... - 30 -

4. High-voltage lines ..... - 31 -

5. Safety belt ..... - 31 -

6. Faults ..... - 31 -

7. Further precautions ..... - 32 -

8. After use ..... - 32 -

9. Remote control ..... - 33 -

MAINTENANCE

1. General ..... - 34 -

2. Maintenance and test ..... - 35 -

3. Lubrication points ..... - 47 -

4. Maintenance of battery ..... - 48 -

5. Maintenance of internal-combustion engine ..... - 51 -

TROUBLE-SHOOTING

1. General ..... - 52 -

2. Stabilizers cannot be lowered ..... - 52 -

3. The boom cannot be raised ..... - 52 -

4. The boom cannot be lowered ..... - 53 -

5. The boom cannot be telescoped outwards ..... - 53 -

6. The boom cannot be telescoped inwards ..... - 53 -

7. The lift cannot turn to the right or to the left ..... - 54 -

8. Too short operating time on the battery ..... - 54 -

9. No charge indicator deflection ..... - 54 -

10. Indication lights for placing do not function appropriately ..... - 54 -

APPENDIX - Order numbers for decals ..... - 56 -

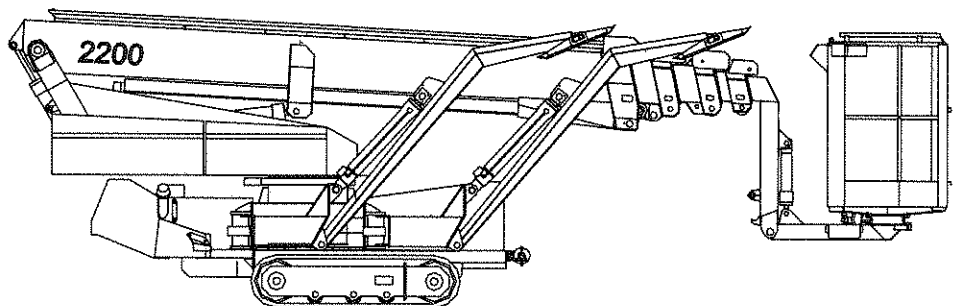
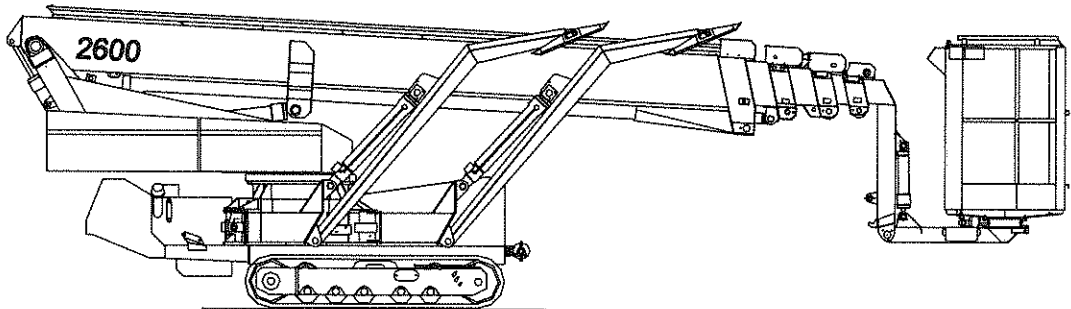
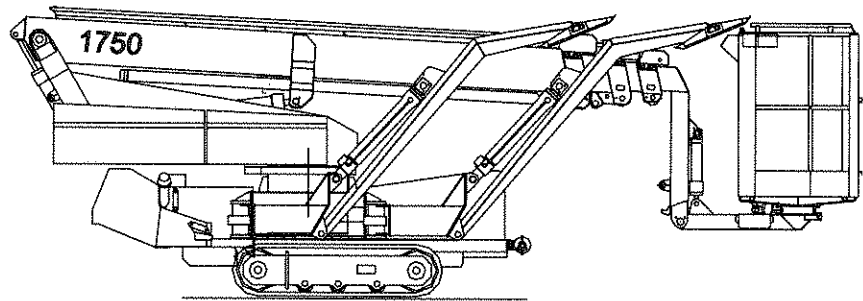
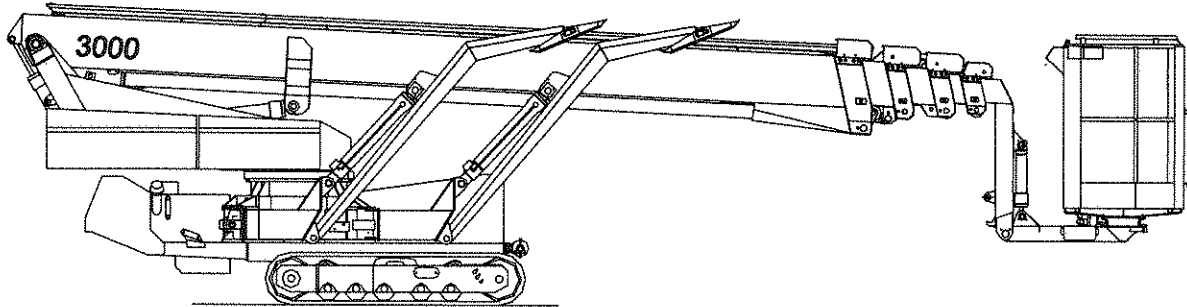
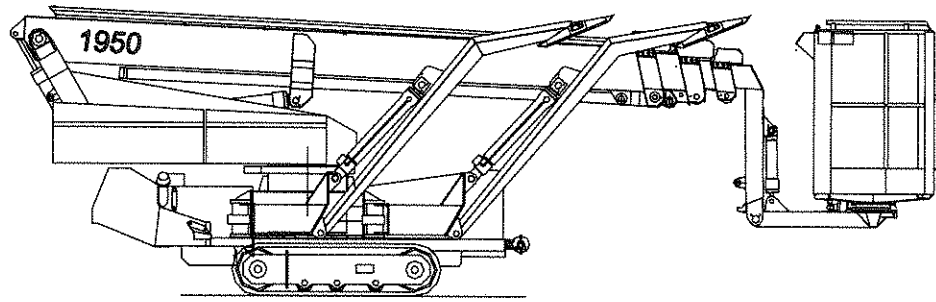



Definition of the lift

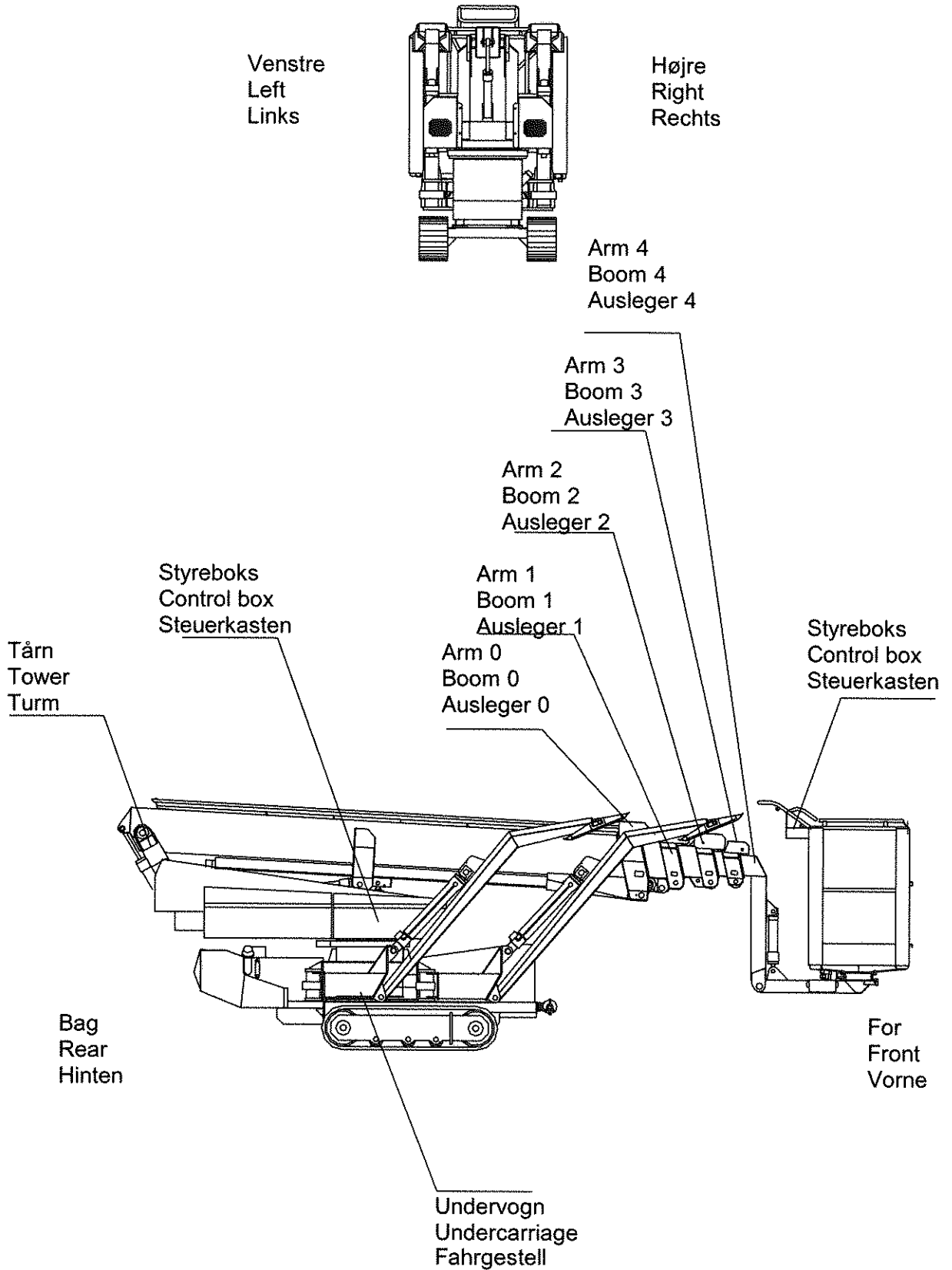

**Safety regulations**

**WHEN OPERATING THE LIFT, PLEASE NOTE!**

Always place the lift correctly and on firm ground. Check spirit level.

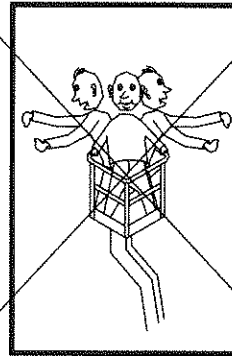
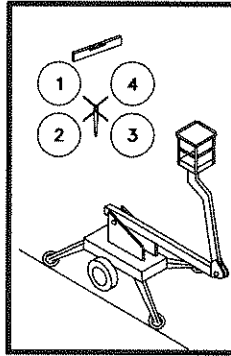

DO NOT use the lift with overload in basket.

DO NOT use the lift at high wind force.

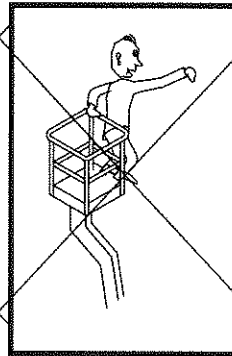
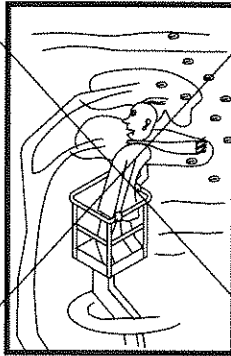

DO NOT leave the basket, before the lift is in transport position.

Always keep the safety regulations, when working near high-voltage lines.

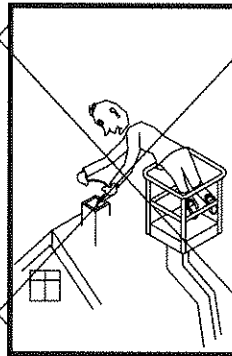
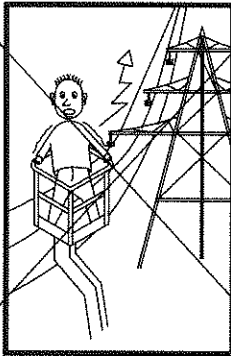

DO NOT lean out over top edge of basket.

DO NOT use a ladder from basket.

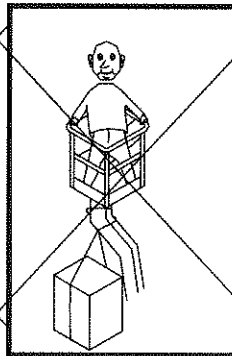
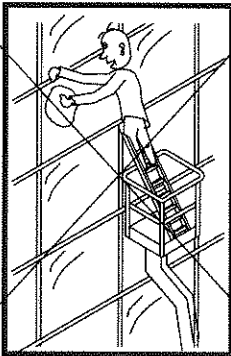

DO NOT use the lift as a crane.

Squeeze danger when staying within the working area of the lift.

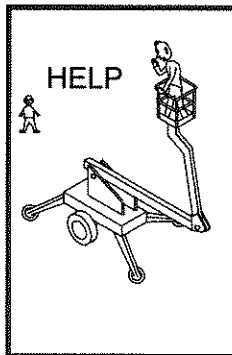
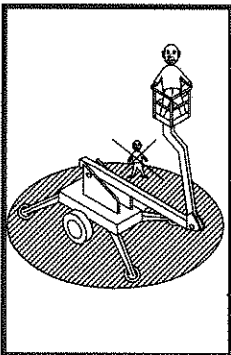

DO NOT use the lift single-handed. Always make sure, to have a colleague near by in case of operation stop (EMERGENCY LOWERING).

### **Description and field of application**

The OMME lift may be used indoors as well as in the open.

The OMME lift is a telescopic lift with hydraulic telescopic extension and a turntable, which makes it possible to place the work basket in the desired working position.

Lift operation is effected by a 24 V DC-motor and/or by an internal-combustion engine. Motor voltage is supplied by batteries, which may be re-charged by means of the built-in charger.

The DC-motor drives a hydraulic motor, pumping oil into the cylinders in order to raise or lower the work platform according to the position of the operation valves. The hydraulic cylinders conform with current DIN-standards.

For rotary movement the hydraulic oil is led through the operation valves to a hydraulic motor, which turns the rim gear of the turntable via a "reduction gear". The drive of the "reduction gear" grasps the rotating parts of the turntable, so that the boom is turned into the desired position.

The OMME lift is mounted on crawlers for use in undulating land.

Maintenance of tracks: Please see the enclosed manual for the applied tracks.

Operation of the jib boom can only take place from the basket. By operation of the jib boom it is not possible to use the functions out and down.

The hydraulic to the jib boom is supplied by a pumping station, which is mounted in the basket. The hydraulic pump is powered by a 24 V motor.

The OMME lift has sturdy electrical control handles.

The OMME-lift movements are performed with continuously variable speed, so that it is possible to reach the desired working position in a fast and accurate way.

The work basket - which is of aluminium tube - has a grip edge all the way round. The grip edge is placed on the inside in order to avoid hand injuries. The work basket provides safe footing in all positions.

**Battery operation:** The sound pressure of the machine is lower than 75 dB (A) at the control boxes.

**Engine operation:** Ear defender recommended, when lift is driving on the tracks.

**1750 R**

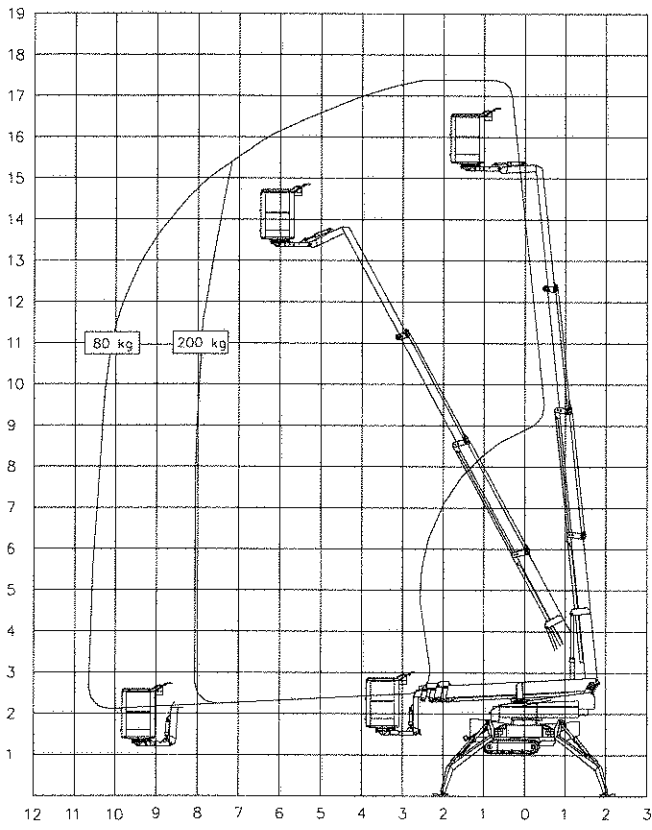

**1900 RJ**

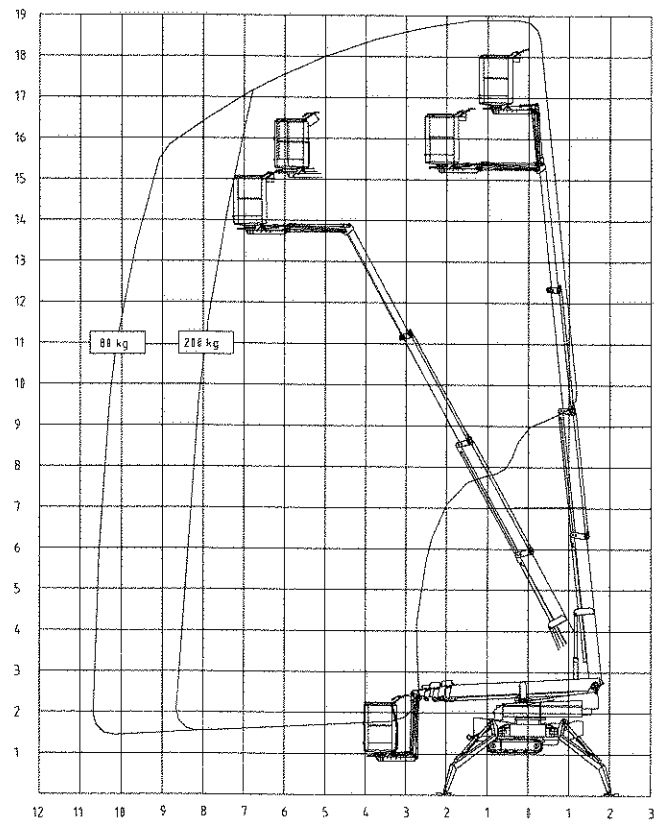

**1950 R**

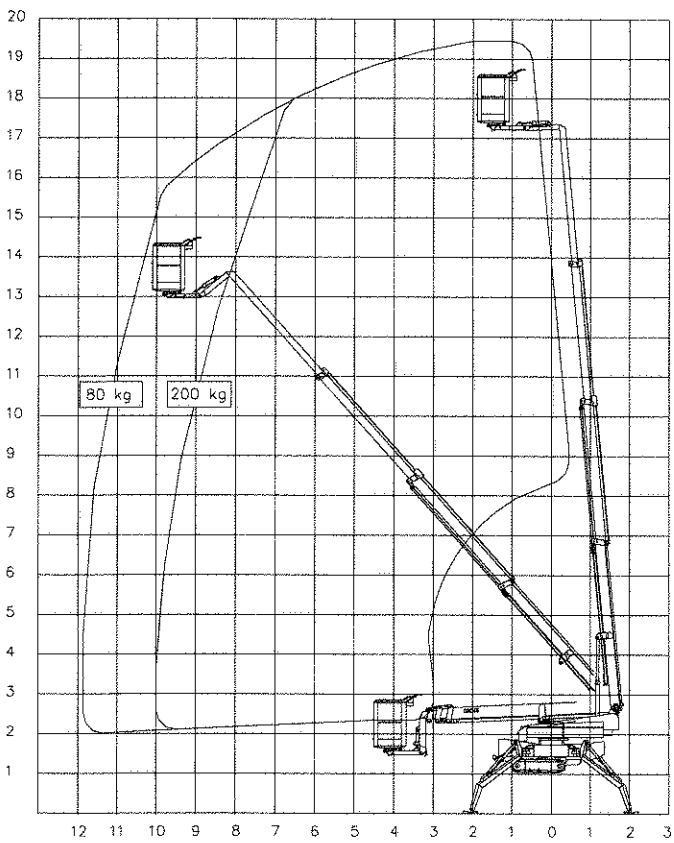

**2100 RJ**

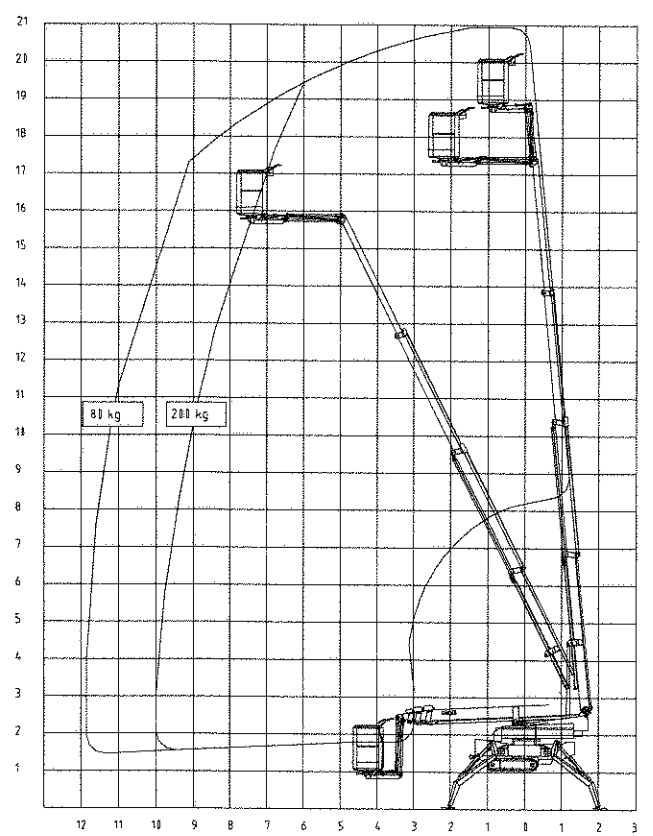

**2200 R**

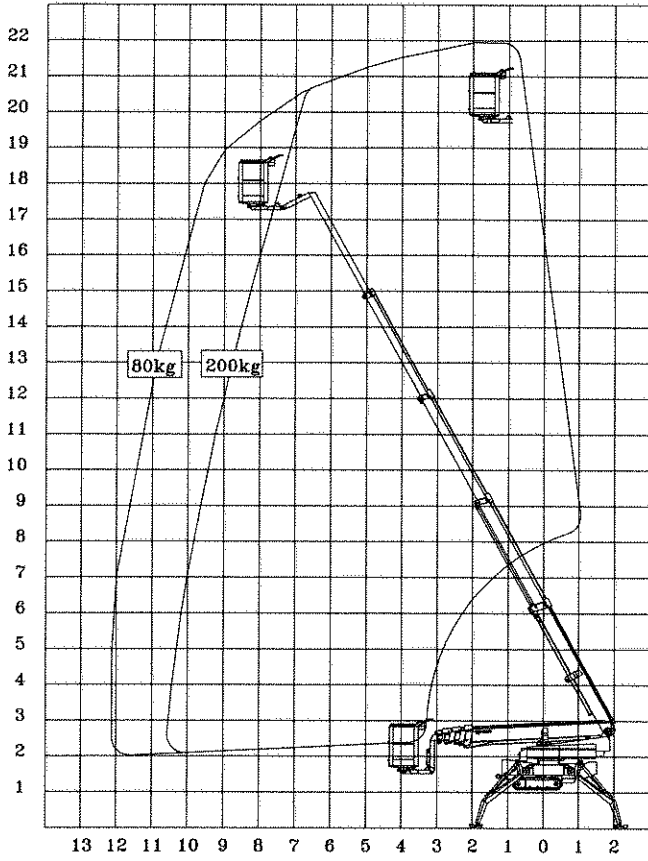

**2350 RJ**

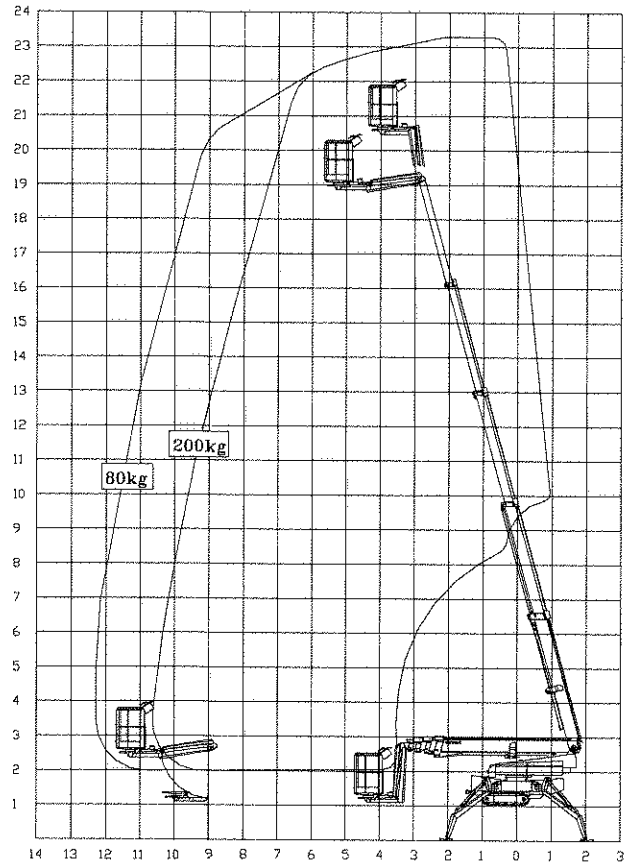

**2600 R**

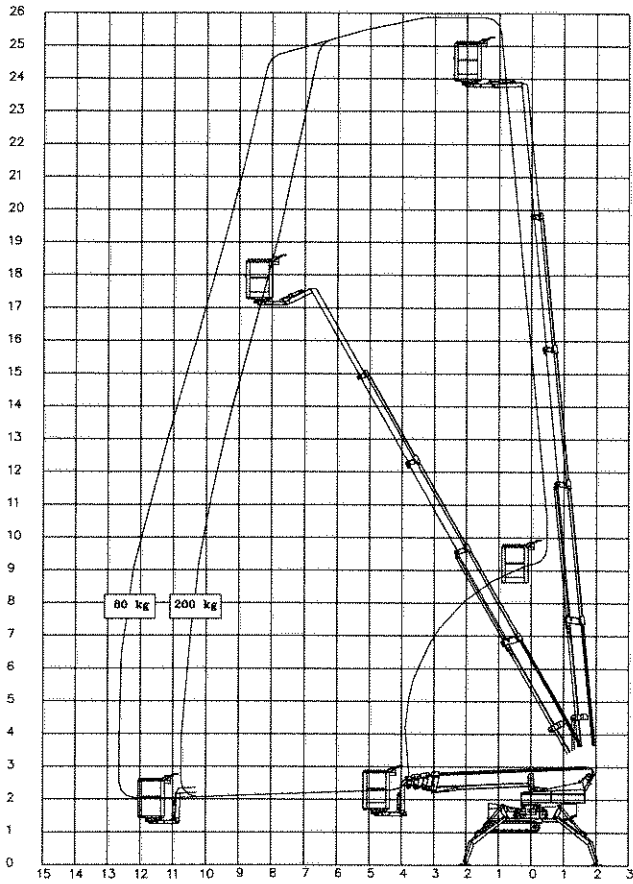

**2750 RJ**

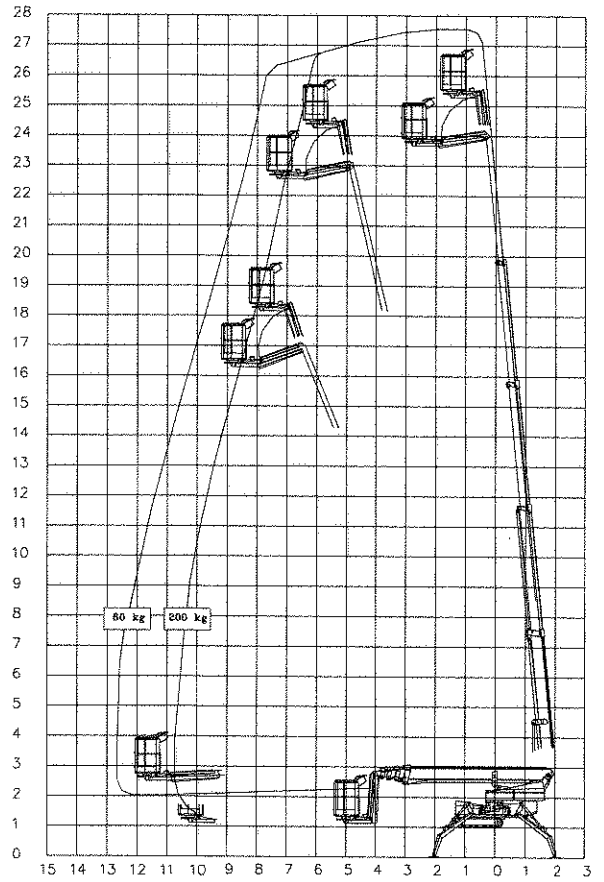

**3000 R**

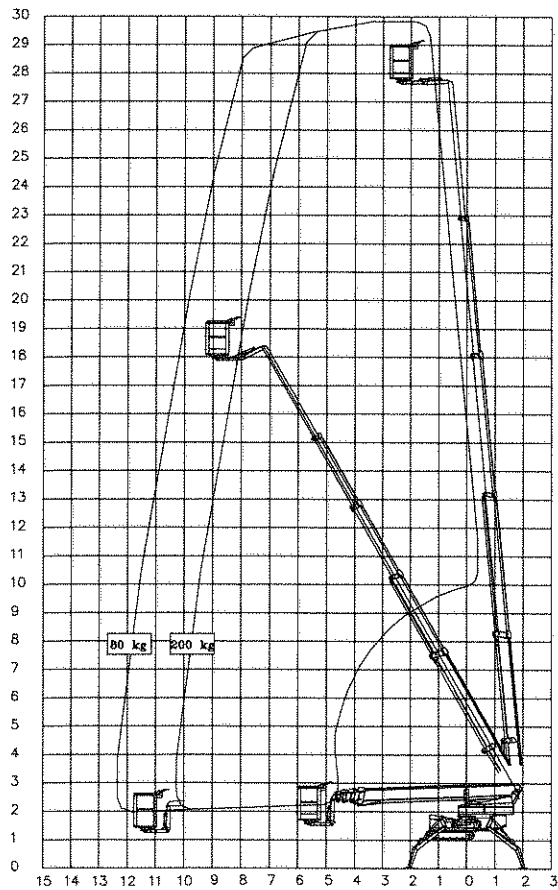

**3150 RJ**

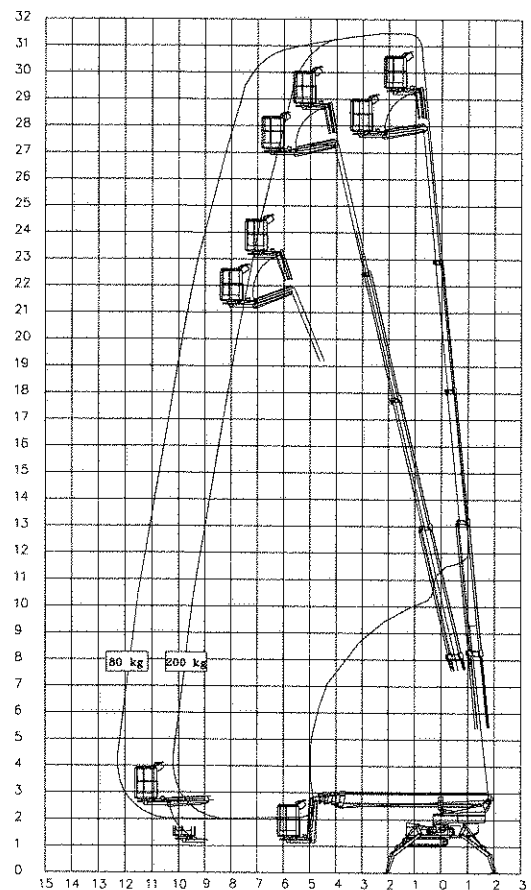

Technical data:	1930 RXD	1930 RXBD	1750 RD	1750 RBD	1950 RD	1950 RBD	2200 RD	2200 RBD	2600 RD	2600 RBD	3000 RD	3000 RBD
Lift type	Scissor/Telescope	Telescope	Telescope	Telescope	Telescope	Telescope	Telescope	Telescope	Telescope	Telescope	Telescope	Telescope
Max. working height, m	19.1 m	17.2 m	17.2 m	19.3 m	19.3 m	21.8 m	21.8 m	25.6 m	25.6 m	29.7 m	29.7 m	30.0 m
Max. outreach, m	10.2 m	10.4 m	10.4 m	11.7 m	11.7 m	12.2 m	12.2 m	12.6 m	12.6 m	12.6 m	12.6 m	12.6 m
Max. basket load, kg	200 kg	200 kg	200 kg	200 kg	200 kg	200 kg	200 kg	200 kg	200 kg	200 kg	200 kg	200 kg
Rotation	± 355°	± 355°	± 355°	± 355°	± 355°	± 355°	± 355°	± 355°	± 355°	± 355°	± 355°	± 355°
Basket size, m	1.25x0.8x1.1 m	1.25x0.8x1.1 m	1.25x0.8x1.1 m	1.25x0.8x1.1 m	1.25x0.8x1.1 m	1.25x0.8x1.1 m	1.25x0.8x1.1 m	1.25x0.8x1.1 m	1.25x0.8x1.1 m	1.25x0.8x1.1 m	1.25x0.8x1.1 m	1.25x0.8x1.1 m
Turnable basket	± 41°	± 41°	± 41°	± 41°	± 41°	± 41°	± 41°	± 41°	± 41°	± 41°	± 41°	± 41°
Battery	24V/200Ah/5h	24V/200Ah/5h	24V/200Ah/5h	24V/200Ah/5h	24V/200Ah/5h	24V/200Ah/5h	24V/200Ah/5h	24V/200Ah/5h	24V/200Ah/5h	24V/200Ah/5h	24V/200Ah/5h	24V/200Ah/5h
Charger	24 V/30 A	24 V/30 A	24 V/30 A	24 V/30 A	24 V/30 A	24 V/30 A	24 V/30 A	24 V/30 A	24 V/30 A	24 V/30 A	24 V/30 A	24 V/30 A
Transformer	O	O	O	O	O	O	O	O	O	O	O	O
Diesel engine	14 kW/18.8 hp	14 kW/18.8 hp	14 kW/18.8 hp	14 kW/18.8 hp	14 kW/18.8 hp	14 kW/18.8 hp	14 kW/18.8 hp	14 kW/18.8 hp	14 kW/18.8 hp	14 kW/18.8 hp	14 kW/18.8 hp	14 kW/18.8 hp
Generator	24 V/22 A	24 V/22 A	24 V/22 A	24 V/22 A	24 V/22 A	24 V/22 A	24 V/22 A	24 V/22 A	24 V/22 A	24 V/22 A	24 V/22 A	24 V/22 A
Transport length	5.90 m	5.80 m	5.80 m	6.30 m	6.30 m	6.40 m	6.40 m	7.20 m	7.20 m	8.00 m	8.00 m	8.00 m
Transport height	2.07 m	1.99 m	1.99 m	1.99 m	1.99 m	1.99 m	1.99 m	1.99 m	1.99 m	1.99 m	1.99 m	1.99 m
Transport width	1.10 m	1.10 m	1.10 m	1.10 m	1.10 m	1.10 m	1.10 m	1.10 m	1.10 m	1.10 m	1.10 m	1.10 m
Operational width	4.60/3.75 m	4.60/3.75 m	4.60/3.75 m	4.60/3.75 m	4.60/3.75 m	4.60/3.75 m	4.60/3.75 m	4.60/3.75 m	4.60/3.75 m	4.60/3.75 m	4.60/3.75 m	4.60/3.75 m
Total weight	3150 kg	3250 kg	2800 kg	2900 kg	2880 kg	3000 kg	3000 kg	3500 kg	3500 kg	3650 kg	3650 kg	3775 kg
Gradeability	19.3° (35%)	21.8° (40%)	21.8° (40%)	21.8° (40%)	21.8° (40%)	21.8° (40%)	21.8° (40%)	19.3° (35%)	19.3° (35%)	19.3° (35%)	19.3° (35%)	19.3° (35%)
Deployment ability	21.8° (40%)	21.8° (40%)	21.8° (40%)	21.8° (40%)	21.8° (40%)	21.8° (40%)	21.8° (40%)	21.8° (40%)	21.8° (40%)	21.8° (40%)	21.8° (40%)	21.8° (40%)
Crawler track length	1.42 m	1.42 m	1.42 m	1.42 m	1.42 m	1.42 m	1.42 m	1.74 m	1.74 m	1.74 m	1.74 m	1.74 m
Number of supporting rollers	3	3	3	3	3	3	3	4	4	4	4	4
Hydraulic stabilizers	+	+	+	+	+	+	+	+	+	+	+	+
Proportional controls	+	+	+	+	+	+	+	+	+	+	+	+
Hydraulic propulsion	+	+	+	+	+	+	+	+	+	+	+	+
230 V outlet in basket	+	+	+	+	+	+	+	+	+	+	+	+
Jib-movable	+	+	+	+	+	+	+	+	+	+	+	+
Wireless remote control, propulsion	O	O	O	O	O	O	O	O	O	O	O	O
White tracks	O	O	O	O	O	O	O	O	O	O	O	O

+ Standard O Optional + Not available

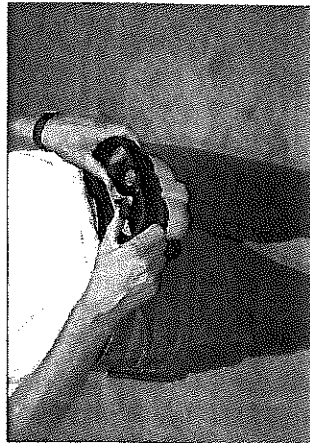

Drive operation: Standard via wired remote control.  
Optional wireless control.

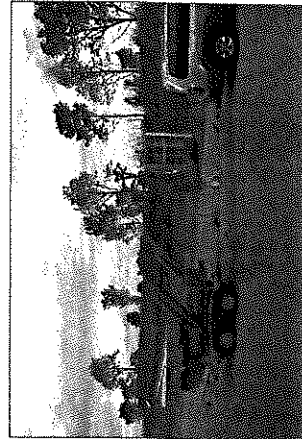

Transport on a purpose built trailer.  
Up to type 2200, the total weight is less than 3500 kg.

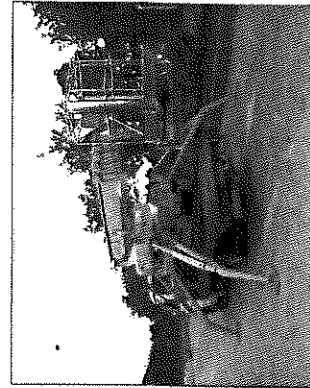

Transport on a small truck without a ramp.



Transport on a truck with a ramp.

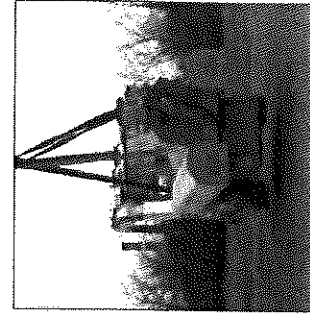

Lifting eyes are fitted.

Visit our home page [www.ommelift.dk](http://www.ommelift.dk) for additional data and photos

OMME LIFT A/S

Lægårdsvvej 4 - DK - 7260 Str. Omme

Tel. +45 75 34 13 00 - Fax. +45 75 34 15 92

[www.ommelift.dk](http://www.ommelift.dk)

OMME  
Lifts - all kinds





### **Operation of the internal-combustion engine**

**Always** check the motor oil level before the internal-combustion engine is started. Activate the main switch (B). Place the key reverser (2) into position "tower" (2c).

Start of internal-combustion engine: Hold the knob in position "START". The engine will not start, until the preheating has ended. Lasts about 4 sec.

A knob is also placed in the basket. To use this function, it is necessary that the key reverser in tower is turned into "basket operation" and that the lift is placed correctly.

When the internal-combustion engine is stopped or if the engine misfires, the electric motor is activated automatically.

**Note!** Do not activate the starter continuously for more than 10 seconds. After that a cooling brake of 60 seconds is necessary. If these guidelines are not being observed the starting motor may "burn out".

**Important!** Always make sure that the batteries are fully charged, and that the fuel tank is full before starting to work.

Maintenance of the engine: Please see in the enclosed manual for the applied engine.



## **STARTING OMME LIFT**

### **1. Instructions**

- 1.1 The lift may only be placed on firm ground. The wind velocity must not exceed 12.5 m/sec.
- 1.2 Only persons, who meet the national demands to persons operating the lift, may operate it.
- 1.3 On the working site there must always be persons present, who in any emergency situation can bring down the operator of the lift.
- 1.4 When working on public roads, warnings and barriers must be mounted in accordance with the national traffic code.
- 1.5 **IMPORTANT!** When the lift is in operation, the user must always take care, that no persons are within the working area of the tower - **squeeze danger**.
- 1.6 Activate main switch (B).
- 1.7 To use the propulsion (tracks) the lift must be placed in "transport position". The boom must be placed in lowest position and the tower must be locked (handle (H) on the tower front must be in lowest position).
- 1.8 It is possible to raise the lift boom to overcome grades. Turn key reverser (2) to position "tower operation" (2c). Reset the system by activating operation handle (6) "boom up" or operation handle (5) "telescope in". The lifting cylinder is automatically interrupted, when max. lifting height is reached. On lifts with movable jib boom it can also be necessary to raise the jib boom to overcome grades. Turn key reverser (2) to position "stabilizer/propulsion" (2a). Now the jib boom can be raised and lowered when using the switch under the basket (see point 1.27 page 17).
- 1.9 **Lifts with wired remote control:** (see sketch, page 16)

Turn key reverser (2) to position "stabilizer/propulsion" (2a). The 8 red indicators for stabilizer control (7b) and (7c) will come on. The propulsion is operated from the mobile remote control box (F), in which one handle for each track is placed. For driving straight-forward operate the two handles . If internal-combustion engine power is required, then start engine from the mobile remote control box (F).

1.10 **Lifts with wireless remote control:** (see sketch, page 16)

Turn key reverser (2) to position "stabilizer/propulsion" (2a). The 8 red indicators for stabilizer control (7b) and (7c) will come on.

Activate the control box (E) on the right hand side of the box. Turn button to position 1 (green indicator is flashing). Reset the receiver (G) by pushing the green button, placed on the left hand side of the box (horn symbol). **REMEMBER** to reset the remote control (E) each time you switch from "lift operation" (2c) to "stabilizer operation/propulsion" (2a).

The propulsion is operated from the mobile wireless remote control (E), in which one handle for each track is placed. When driving straight-forward operate the two handles.

If internal-combustion engine power is required, then start engine from the box (E) by pushing the small button to the right (+). Stop the engine by pushing the button to the left (-). Emergency stop on the panel is only active for the propulsion system.

If the radio transmitter does not achieve contact with the receiver (G), placed behind rear left stabilizer, see point 9.a, page 33).

1.11 Driving on uneven grounds must be carried out with utmost caution. The lift is equipped with an alarm, which is activated, if the incline limits are reached. If the alarm is activated, then bring back the lift to a safe position immediately. Remove the hindrance or find an alternative route. To avoid any tilting - lower the stabilizers to horizontal position (see drawing, page 19).

1.12 When placing lift on stabilizers the key reverser (2) must be placed in position "stabilizer operation" (2a). The 8 red indicators for stabilizer control (7b) and (7c) will come on.

a. Turn the stabilizers to maximum stabilizer spread (turn pawl arm free of engagement - turn the stabilizer - reengage the pawl). If all pawls are correctly engaged, the 4 indicators (7c) must now be switched off.

b. Lower the stabilizers by means of the 4 control handles (C). Always lower the stabilizers in pairs, rear (1-2) and front (3-4). When raising the stabilizers, these must also be raised in pairs.

- c. Only raise the lift to the level, required for. When the tracks are free of ground, the placing is correct. If lifting to highest level is necessary, this must be carried out with utmost caution. The lift must be raised to about level position, as oblique placing causes a tilting danger.
- d. Lower the stabilizers, until the tracks are free from the ground, and the lift position is horizontal. Check by means of the spirit level (D). If the placing is correct, the 4 indicators (7b) must now be switched off (pressure on all 4 stabilizers). Place key reverser (2) in position lift operation (2c). Now the green indicator for lift operation (7a) must come on. The lift is now ready for use.
- e. **Lifts with automatic stabilizer levelling system up and down**
  - The automatic stabilizer levelling system is operated by means of a rotary knob with 3 positions (13) and a green lamp comes on at correct deployment.
  - Lift deployment: Press the knob "downwards" and keep it activated. The stabilizers move downwards and the movement stops automatically at correct lift deployment and the green lamp comes on. The knob can be activated again, if the lift should be lifted to a higher level. The lift will then raise in upright position, until you release the knob or a maximum height is reached.
  - Taking down the lift: Press the knob "upwards" and keep it activated, until the stabilizers are all up or in the requested position.
  - Generally: If the automatics drive one or more of the stabilizer cylinders all down during deployment - without the lift being placed correctly - it is recommended to press the knob "upwards" for a short moment in order for the high end of the lift to lower slightly. Then press the knob "downwards" enabling the automatics to replace the lift correctly.

The stabilizers can also be operated by means of the manual hydraulic handles.

Before transporting the lift, then check that the stabilizers are placed in transport position or in the required position when driving in terrain.

- 1.13 At lift deployment in narrow places it is possible to place the lift with reduced stabilizer spread to one side. Then it is only possible to operate to the opposite side (see drawing, page 19). The working height is moderately reduced.  
Lifts with adjustable tracks: At reduced stabilizer placement the tracks must be in narrowest position.
- 1.14 Unlock tower (lift handle (H) on the tower front to upper position), before lift operation. Turn key reverser (2) to position basket operation. Bring key along.
- 1.15 Remember, that because of the construction elasticity, a movement does not stop immediately, when releasing the corresponding handle. Avoid bumping into immovable parts, such as walls, masts or trees. Thus start and stop all movements by means of the adjusting knob for low speed (3).
- 1.16 As an extra safety the lift is equipped with a warning device, which is activated, if the placing is no longer at its optimum during work from basket. If the sound continues, then bring the basket into transport position as soon as possible, and check if the placing of the lift is correct, see point 1.1 and point 1.12.d.
- 1.17 If the lift reaches its highest outreach, the red indicator in control box of basket will come on. All outwards and downwards movements are automatically interrupted. Only the movements upwards, inwards and rotation are possible.
- 1.18 If the basket is not completely horizontal, the lift will level automatically. However, this only happens, when the handles for boom "up" or "down" are activated.
- 1.19 If the basket becomes an inclination of more than 10°, when working from basket, all functions are interrupted. Levelling is made manually by means of an assistant. Please see point B in "emergency lowering".
- 1.20 The lift is equipped with manually operated emergency stops (1), which interrupt the lift, when activated.
- 1.21 The lift is equipped with a rotation stop, which only permits one rotation to each side. If the rotation stop is activated, then rotate one turn backwards.
- 1.22 The lift is fitted with an emergency drive control box (see point 9.b, page 33).

- 1.23 At too low voltage on the batteries, the lift movements are interrupted. To bring the work basket to the ground, you can make the lift operate for yet another short while: Push the emergency stop (1) and release it again. Hereafter the work basket must be lowered immediately, so that you can leave the basket. If possible, bring the lift into transport position. Use internal-combustion engine if possible. Before using the lift again, the batteries are to be charged.
- 1.24 If the lift stops during work due to other operation errors, than mentioned in point 1.23, it is possible to bring down the basket by emergency lowering. Please see “emergency lowering”.
- 1.25 After having used the lift, place it in transport position. The main switch (B) and the key reverser (2) are interrupted (2b). When leaving the lift, secure it against being used by unauthorized persons. Bring the key along.
- 1.26 When using power supply for charging or for work in the basket, be careful that the cable is not damaged during propulsion.

**IMPORTANT!** Remember to charge the batteries each night. When it is possible, the charger can also be connected to 230 V, when the lift is in operation.

During all work with the lift, it is important to be aware, that the safety installations are intact, and that damages are repaired at once. The safety of the user is dependent on the condition of the lift.

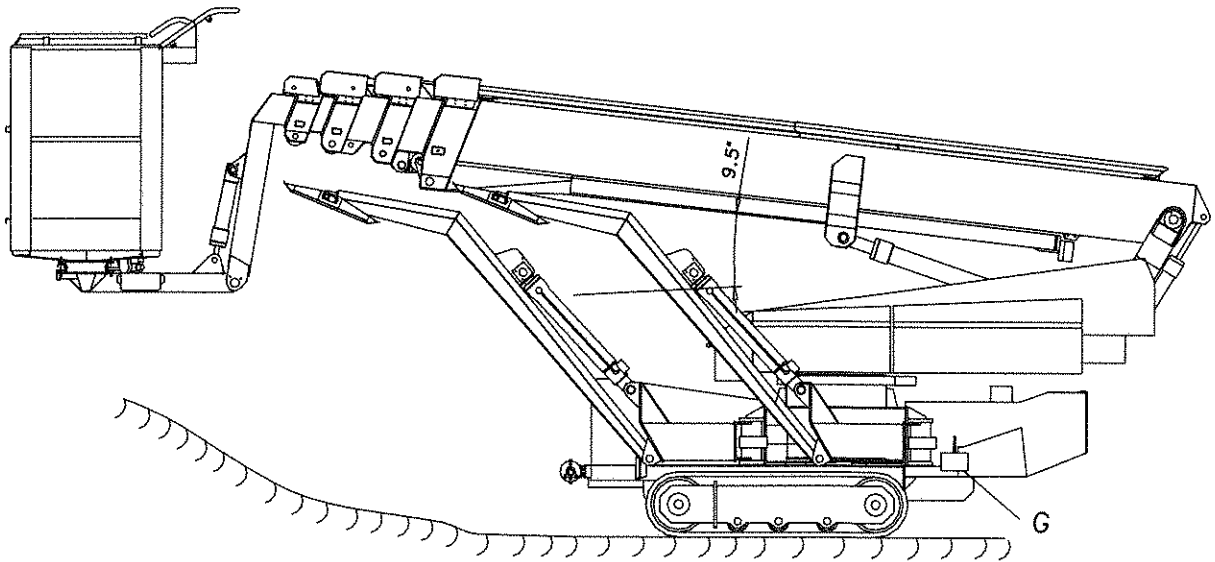
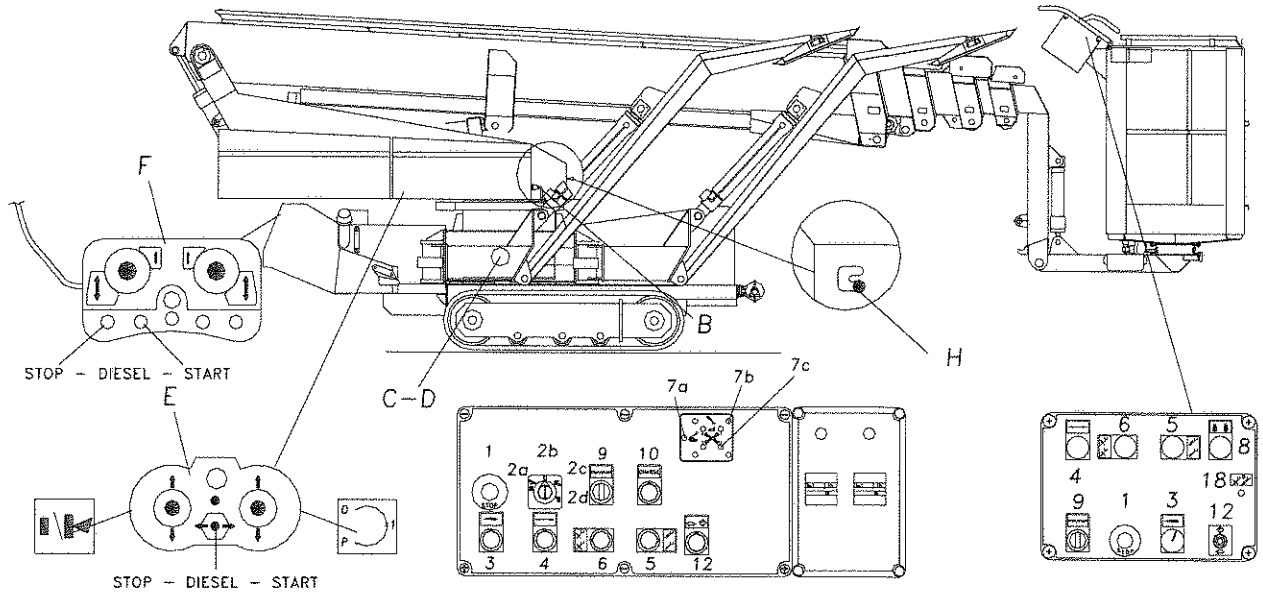



## 1.27 Lifts with movable jib boom:

### Operation of movable jib boom

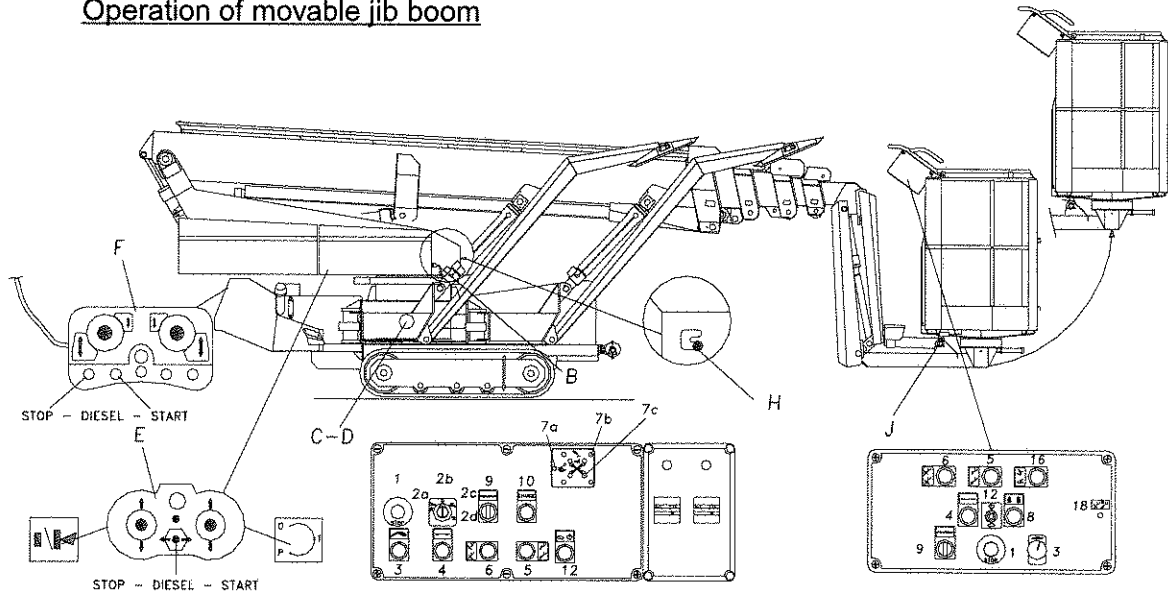

By activating the handle (16) "jib boom" it is possible to raise and lower the boom. Please note that raising and lowering of the jib boom is not possible when the lift reaches its highest outreach (see point 1.17 page 14). The lift boom must now either be raised or telescoped so much inwards that the check load moment control is reactivated. Now it is possible to use the movable jib boom again.

### Raising of the jib boom to overcome grades:

1. Turn key reverser (2) to position tower operation (2c).
2. Reset the system by activating the handle (6) "boom up" or by activating the handle (5) "telescopic boom in".
3. Turn key reverser (2) to position basket operation (2d).
4. The jib boom can now be raised and lowered by activating the switch (J) under the basket.

**Basket in narrow transport position**

Turn the basket to the side, where the spindle motor (1) becomes shortest. Turn the control box (2) into the basket.

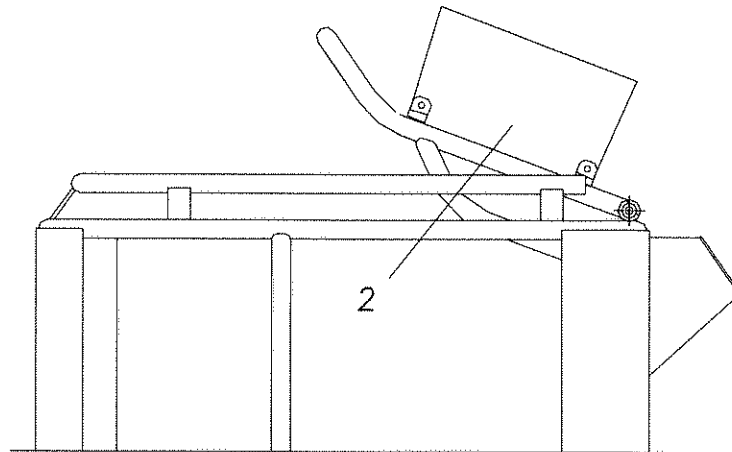

Remove the nail (3), turn the basket manually and remount the motor with the nail (3) in point (4).

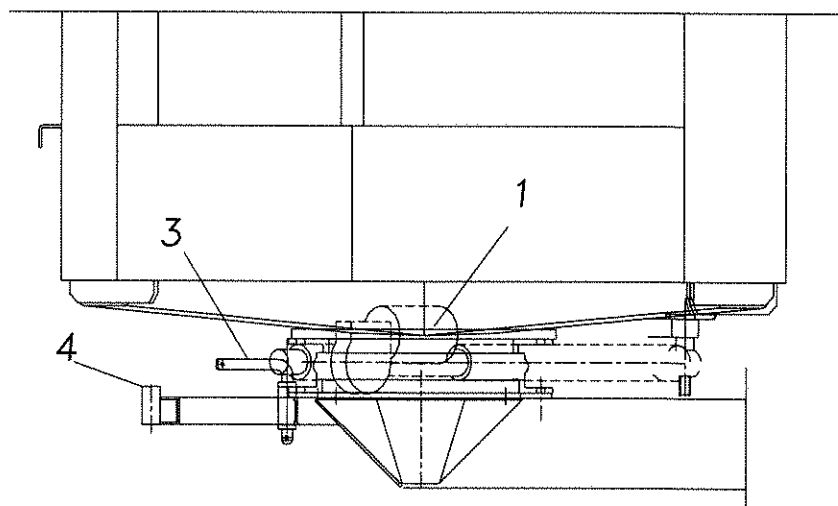

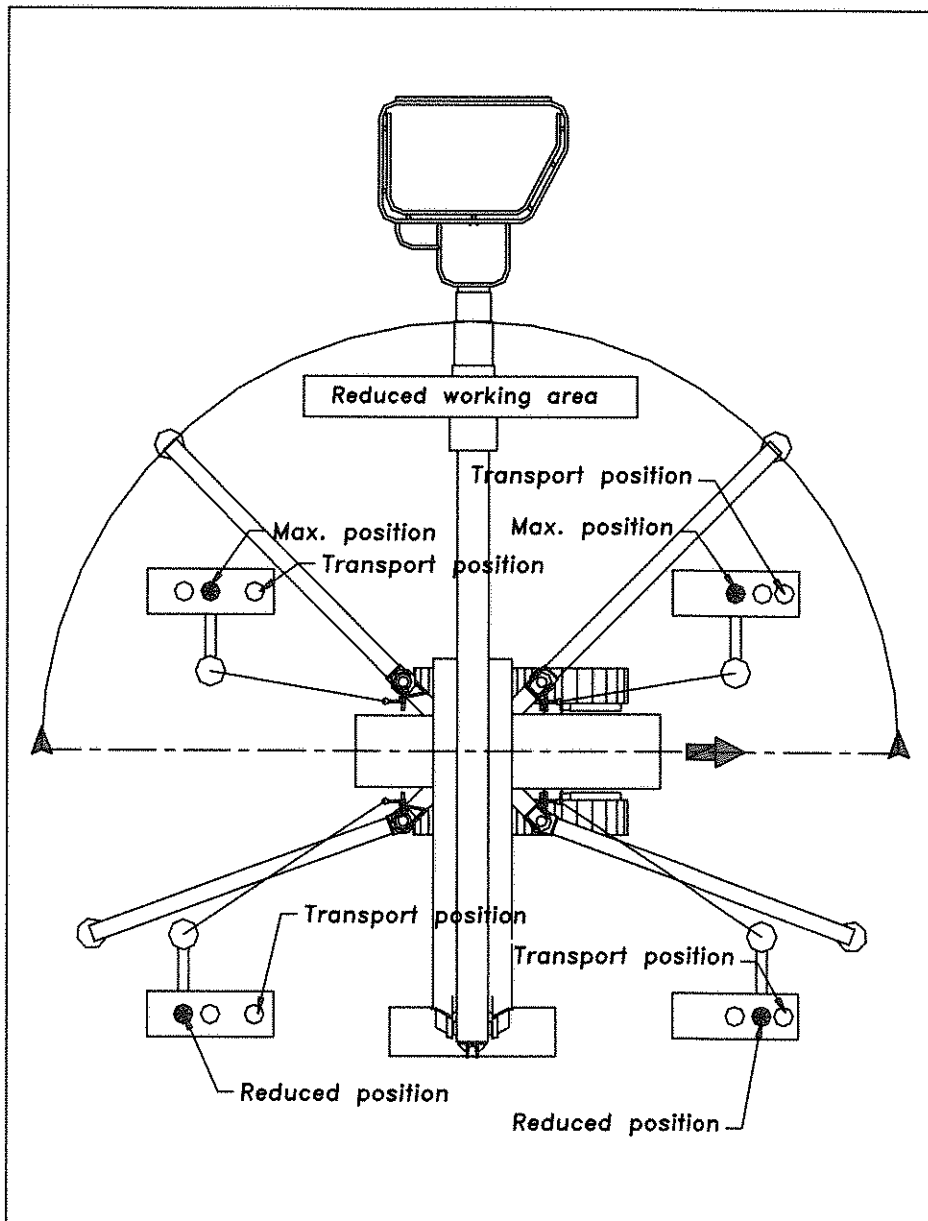
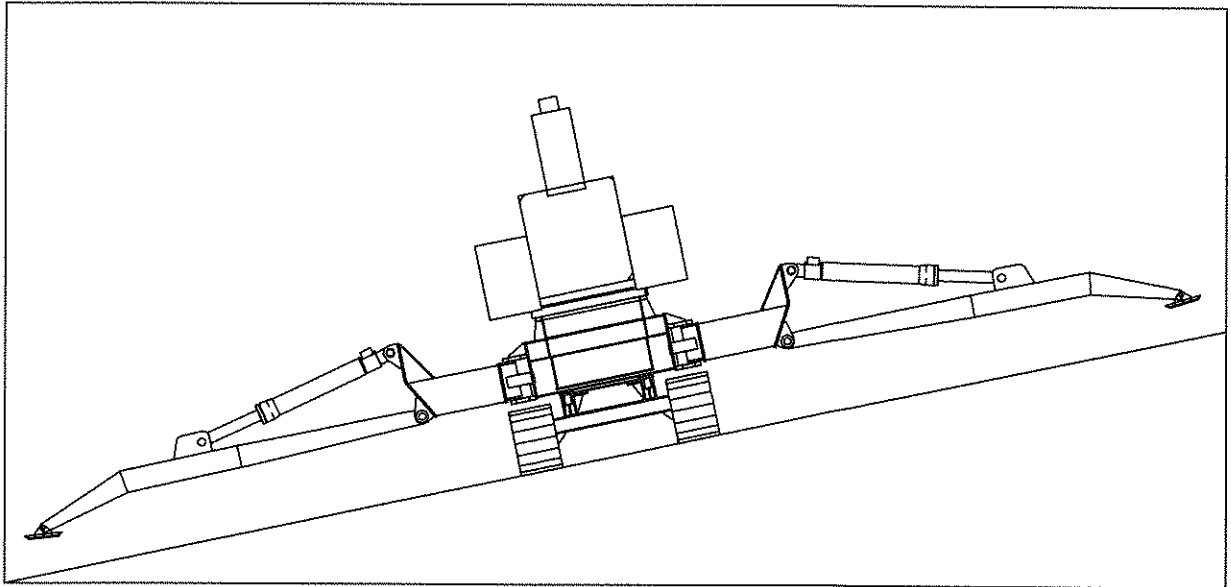

**Stabilizer positions**

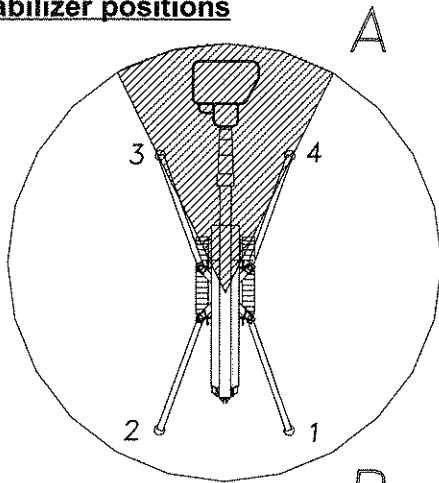

All stabilizers, locked in reduced position.

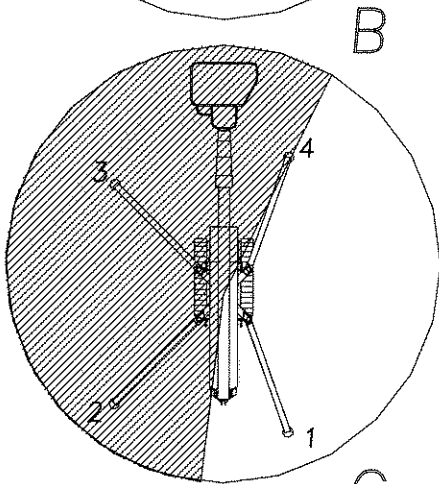

Stabilizer 1 and 4, locked in reduced position.  
Stabilizer 2 and 3, locked in maximum position.

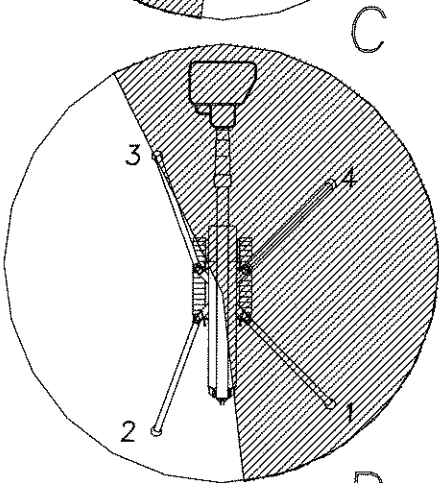

Stabilizer 2 and 3, locked in reduced position.  
Stabilizer 1 and 4, locked in maximum position.

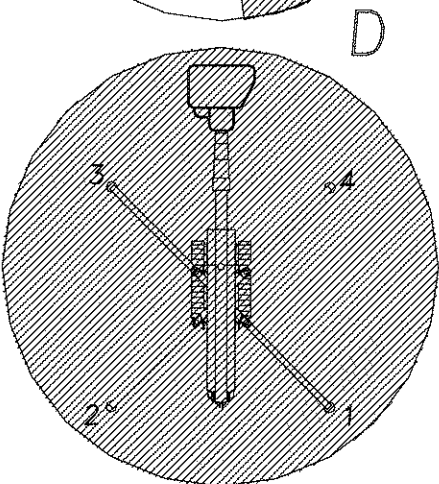

All stabilizers, locked in maximum position.

*Working area = shaded area*

## 2. **A- Emergency lowering**

- 2.1 If the lift stops during work, and it is not possible to locate the fault, an emergency lowering has to be made. If the fault is due to basket inclination over 10° - please see paragraph B.

During manual emergency lowering all safety limit switches are out of operation. Therefore emergency lowering must be made very carefully and according to the descriptions below. Manual emergency lowering requires assistance from the ground.

- 2.2 **Before emergency lowering, the telescopic boom must be pumped in.** If there are any obstacles to the boom being lowered to alighting height, use the barring gear.

The tools required for emergency lowering are: One red handle for hand pump and two red emergency lowering bows. The handle and the red emergency lowering bows are placed in left side box, next to the valve block in the tower.

**IMPORTANT!** When emergency lowering, **always** remember to pump in the telescopic boom first.

Follow the below instructions: Activate emergency stop in basket or tower.

### Manual inwards telescoping of telescopic boom

1. Turn the handle on the three-way cock (A), in order for it to point away from the valve block (position 2). The cock is placed at the valve block.
2. Close valve on hand pump (C). The pump is placed at right rear stabilizer.
3. Place the red extension handle on hand pump (C).
4. Activate magnet valve MV59 (*not mounted on type RB/RBJ*), placed at internal-combustion engine, by means of the one red bow and activate MV41 mechanically by means of the other red bow (see sketch, page 24). Squeeze the bow over the valve, so that the small bolt activates the sleeve valve through the opening of the magnet coil on the valve and opens the valve.
5. Pump in the telescopic boom.
6. Open valve on hand pump (C).

7. Remove bows for valves.
8. Turn the handle on the three-way cock (A) back again (position 1).

Manual operation of the barring gear

1. Turn the handle on the three-way cock (A), in order for it to point away from the valve block (position 2). The cock is placed at the valve block.
2. Close valve on hand pump (C). The pump is placed at right rear stabilizer.
3. Place the red extension handle on hand pump (C).
4. Activate magnet valve MV59 (*not mounted on type RB/RBJ*), placed at the internal-combustion engine, by means of the one red bow and activate MV03 = left or MV01 = right by means of the other red bow. Squeeze the bow over the valve, so that the small bolt activates the sleeve valve through the opening of the magnet coil on the valve and opens the valve. Further, turn the thumb screw MV04 = left or the thumb screw MV02 = right. See sketch at valves.
5. Turn the lift by means of the hand pump (C).
6. Open valve on hand pump (C).
7. Remove bows for valves.
8. Turn the thumb screw (B) on MV02 - MV04 back again.
9. Turn the handle on the three-way cock (A) back again (position 1).

**NOTE! At reduced stabilizer position the lift must never be rotated in to the reduced area. The lift will then tilt.**

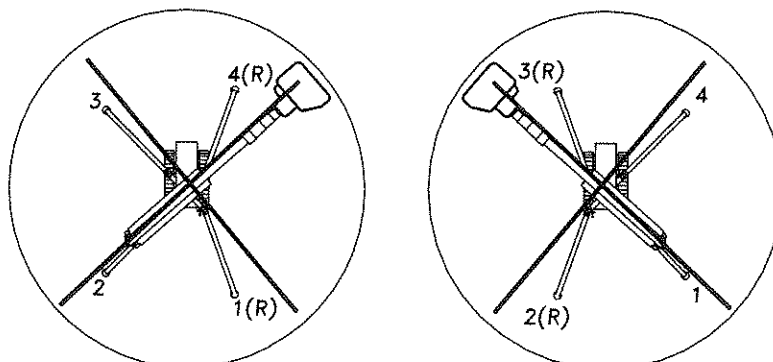

- 2.3 Lowering of lift boom cannot take place, before the telescope is in. Pull out the red button (D) on the valve block of the lifting cylinder. **Take care, squeeze danger**, when the boom is lowered.
- 2.4 Having emergency lowered the lift, check the lift for errors and damages. Check that all emergency lowering valves are closed. Repair errors and damages, if any, before using the lift again.

### **B - Basket inclination of more than 10°**

If the basket is more than 10° oblique, and the lift functions therefore do not take place, then bring the basket back in the following way:

1. Turn the handle on the three-way cock (A), in order for it to point away from the valve block (position 2). The cock is placed at the valve block.
2. Close valve on hand pump (C). The pump is placed at right rear stabilizer.
3. Place the red extension handle on hand pump (C).
4. Activate magnet valve MV59 (*not mounted on type RB/RBJ*), placed at the internal-combustion engine, by means of the one red bow and activate MV49 = basket upwards or MV51 = basket downwards by means of the other red bow. Squeeze the bow over the valve, so that the small bolt activates the sleeve valve through the opening of the magnet coil on the valve and opens the valve.
5. Bring the basket into horizontal position by means of the hand pump (C).
6. Open valve on hand pump (C).
7. Remove bows for valves.
8. Turn the handle on the three-way cock (A) back again (position 1).

Faults and damages, if any, are to be repaired, before further use of the lift.

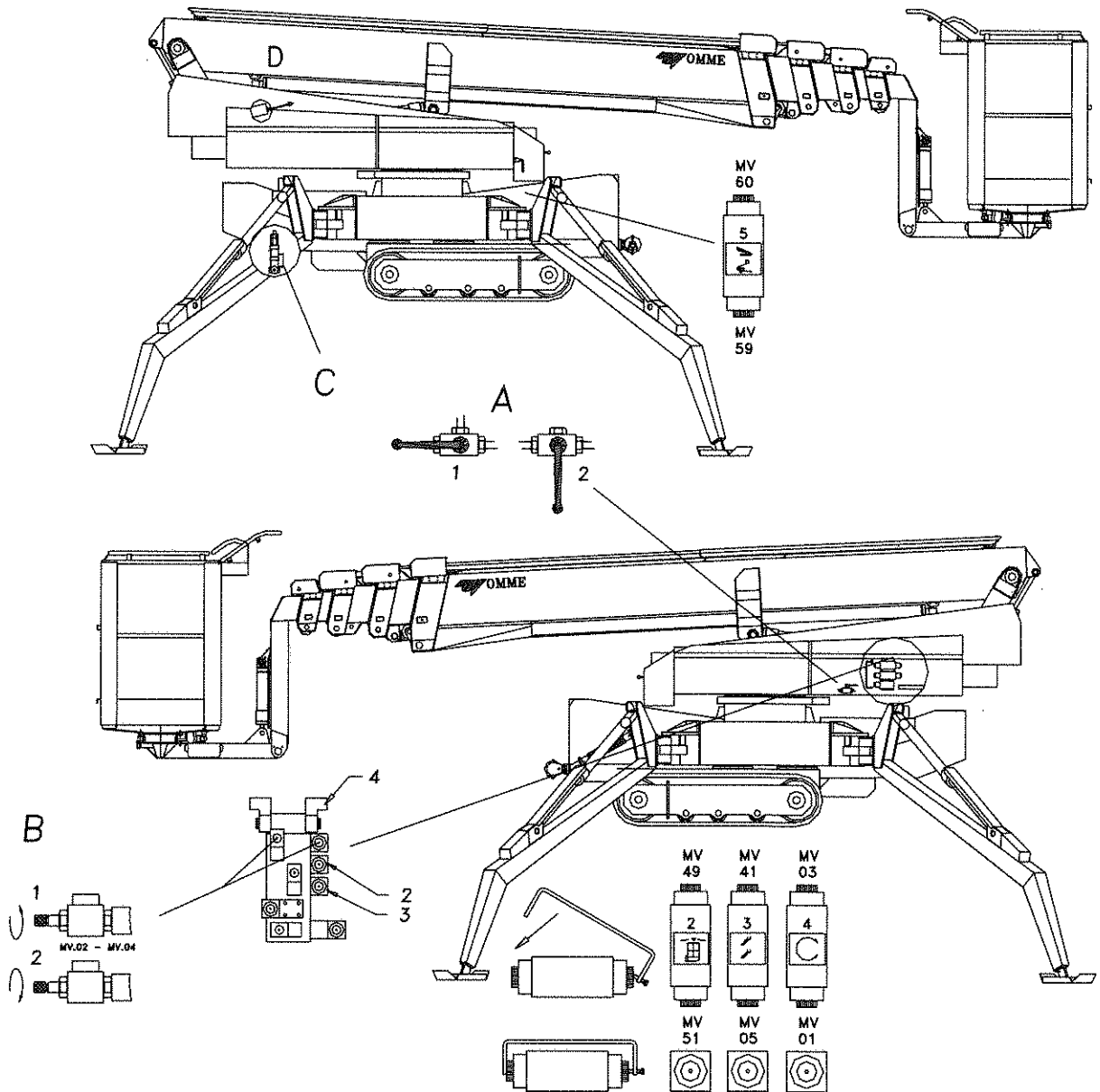

Magnet valve functions

- MV59 Lift control
- MV41 Telescopic boom in
- MV03/ Rotation left
- MV04 Rotation left (thumb screw)
- MV01/ Rotation right
- MV02 Rotation right (thumb screw)
- MV49 Basket upwards
- MV51 Basket downwards



### 3. Manual control of stabilizers

Manual raising of stabilizers must be carried out by 2 persons.

1. Close the valve on the hand pump.
2. Place the red extension handle on the hand pump.
3. Activate the magnet valve MV60 mechanically by means of the red fittings (see instruction), which is placed over the magnet valve, so that the bolt end activates the actual magnet.
4. Raise the stabilizers one by one with the hand pump by activating the handle for the stabilizer in question. The assistant takes care of activating the handle. Only raise each stabilizer a bit, before changing to next stabilizer.  
**Take care! Tilting danger!**
5. Remove the valve fittings.
6. When all stabilizers are raised, open the cock on the hand pump.

Faults and damages, if any, are to be repaired, before further use of the lift.

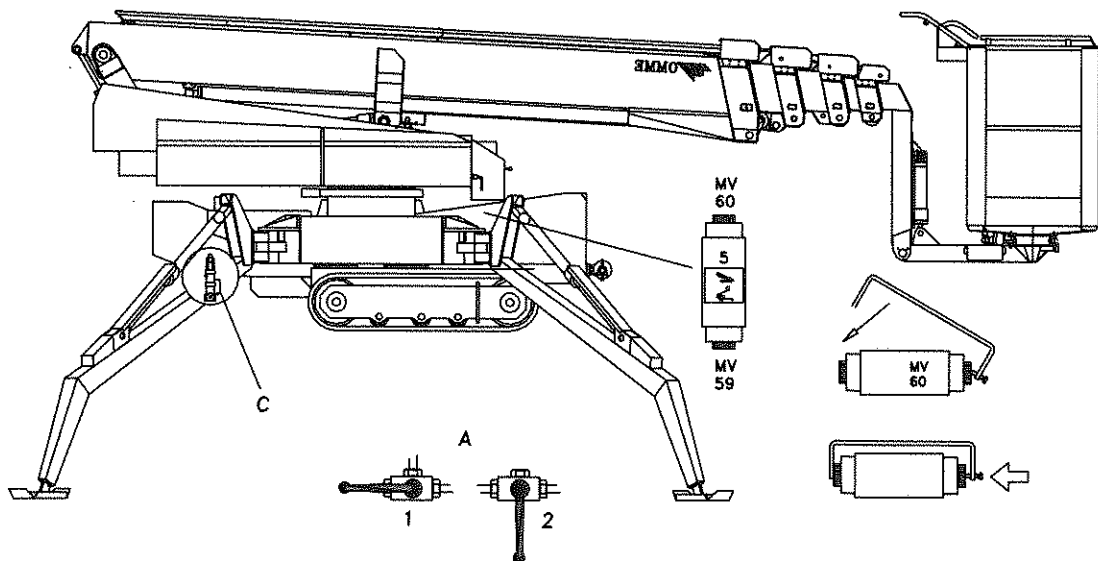

## **HANDLING AND CONDUCT DURING OPERATION**

### **1. Requirements to persons operating the lift**

Anybody operating the lift must be informed about the national safety regulations regarding work platforms.

The lift may only be operated by persons at least 18 years old who have had instruction in using the lift, and who have proved their proficiency to the person responsible.

### **2. Permissible load/lateral force**

The permissible load (200 kg/2000 N in the basket) and the permissible work basket lateral force (40 kp/400 N) must not be exceeded.

### **3. Transport**

When changing place of operation the work basket must not be used. The basket and the stabilizers must be in transport position as shown in the drawing.

At fixing, all 7 fixing eyes of the lift can advantageously be used for reaching an optimal fixing of the lift - lifts with jib boom have 8 fixing eyes. The two eyes at the rear end of the lift and the eye/s at the basket must always be used in order to secure the telescopic booms during transport.

**Note!** Use of the front stabilizers during transport takes place at your own risk.

This is an inappropriate combination, against which must be strongly advised, as this degenerates into extremely strong forces, damaging the lift frame. If you should still decide to use the front stabilizers, then avoid setting pressure on the stabilizers and lower these to only touch the vehicle platform. Take care to continuously check the lift for cracks in the side members for the diesel engine and the crawlers, if the stabilizers are used.

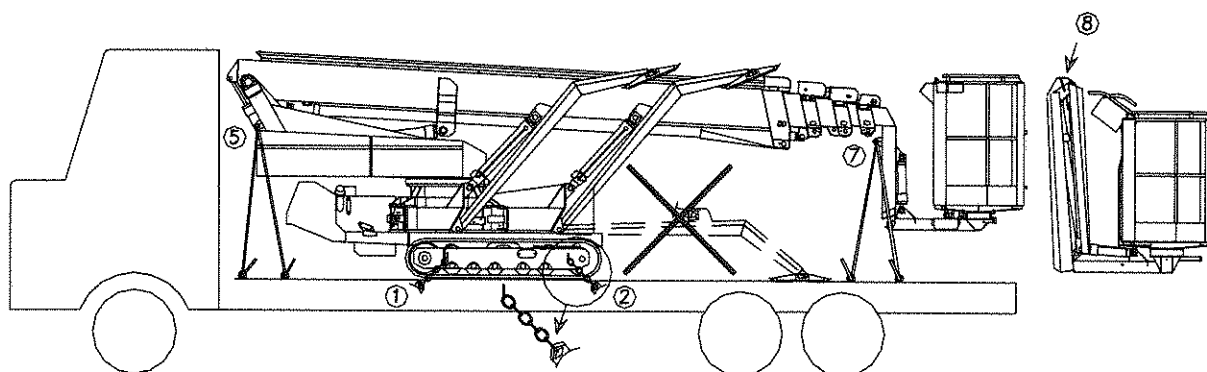

**3.a Lifting procedures**

TABLE OF WEIGHTS				
LIFT TYPE	TOTAL WEIGHT	LIFTS WITH ADJUSTABLE TRACKS	LIFTS WITH JIB	LIFTS WITH ADJUSTABLE TRACKS + WITH JIB
1750 R	2800 kg	3200 kg	2900 kg	3300 kg
1950 R	2900 kg	3300 kg	3000 kg	3400 kg
2200 R	3050 kg	3450 kg	3150 kg	3550 kg
2600 R	3625 kg	4025 kg	3725 kg	4125 kg
3000 R	3775 kg	4175 kg	3875 kg	4275 kg

The person carrying out or supervising this lifting procedure should have the required education for performing the lifting job.

Prior to commencing work an inspection of the lifting gear should be carried out to ensure that all equipment is in good condition.

It is important to use slings of proper strength and length to reach from the hook to the lifting brackets.

If the load is lifted without regard to the position of the centre of gravity, the load will tilt until the centre of gravity is directly below the point of support that is the hook, and the load will be suspended at that angle.

We recommend to use slings of the same length and the minimum length is 3.2 m. It is important that this is complied with, as the lift during lifting must always hang in a backwards angle (please see sketch) and the lift must never tip forwards. Minimum SWL/WLL for the slings is 3000 kg.

The slings are fastened by means of shackles marked with their SWL and WLL showing a minimum of 2500 kg.

If the above recommendations concerning sling length are not followed, the following must be observed:

**The lift must always hang backwards**

**The minimum SWL/WLL of the lifting equipment is 3000 kg**

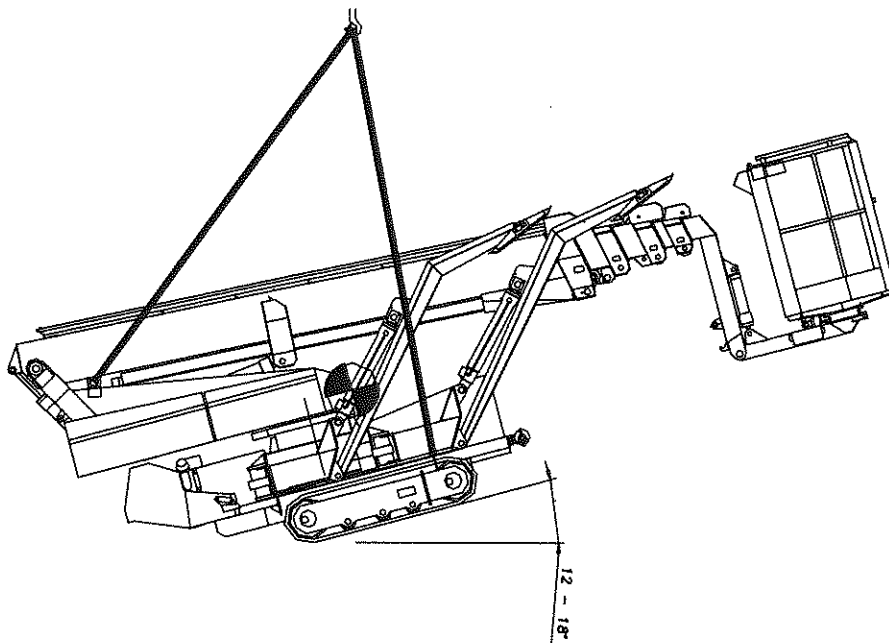
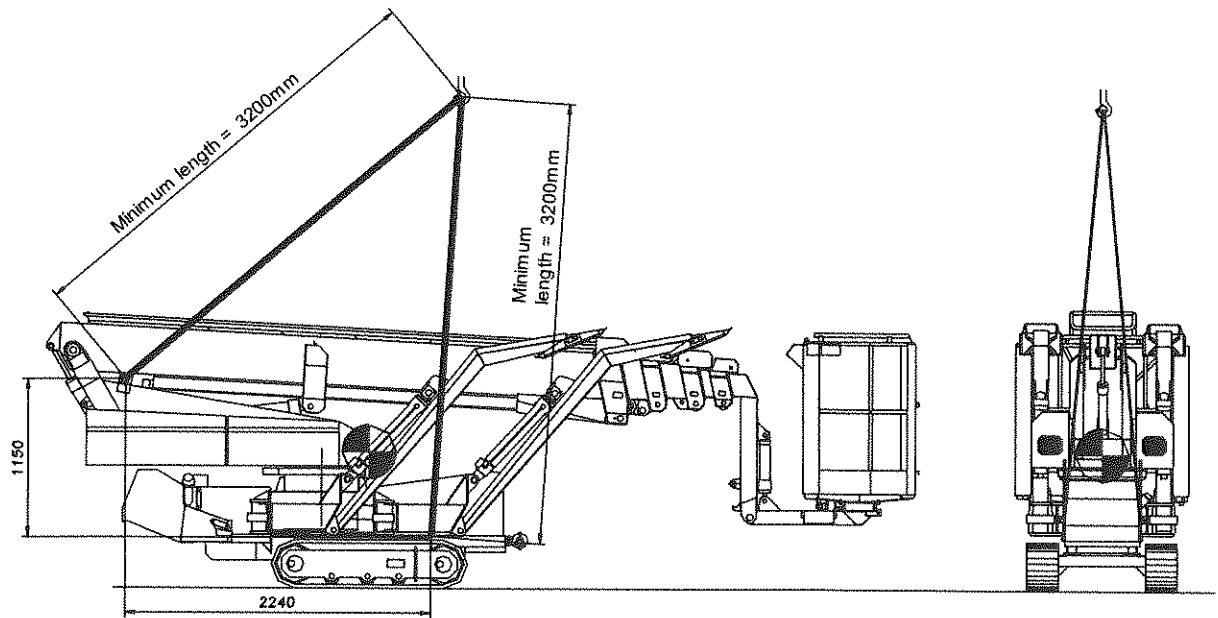

### 3.b Lifting points

There are four holes provided as suitable lifting points.

These holes are located on the lifting fittings that are attached to both sides of the machine i.e. two on each side.

**3.c Lifting the lift**

1. Locate the four lifting points.
2. The platform must be returned to its lowest position.
3. Place the crane hook above the theoretical lifting point of the machine (please see sketch).
4. Ensure the safety latch on the crane hook has secured the oblong link in place.
5. Attach the slings to the bow shackles.
6. Attach the bow shackles to each of the four lifting points and ensure that each pin is screwed fully in place and tightened.
7. Slowly raise the loose slings until the slack is eliminated.

It is extremely important to ensure that the forces in the lifting fittings are vertical and without unnecessary side forces.

8. Check to ensure that all slings and components are straight and no kinks exist.
9. Place some form of protective material e.g. bagging, between the slings and the parts of the machine which may be affected by rubbing and damage the paint work.
10. Ensure that all persons are clear of the machine before lifting.
11. The load is then slowly lifted clear to ensure that it will not move or swing sideways.
12. Check that no persons are in the proposed lifting area.
13. Prior to lifting the machine into place, ensure that the area where it is to be placed is clear of all obstacles, debris and personnel.
14. Be prepared that the lift will move in longitudinal direction, until the lifting angle is in equilibrium.
15. Continue lifting as required and move the machine to near where it is to be placed.

16. Lower the machine.
17. Before slackening or removing the slings, ensure that the machine is secure and cannot roll away etc.
18. Remove the shackles in the lifting fittings.
19. Store all the lifting gear carefully after inspecting it for damage.
20. Report any damage that may have occurred to either the machine or the lifting gear to a supervisor.

**3.d Lifting beam**

Where headroom is limited or the lifting slings may cause damage to the machines structure or paintwork, it may be necessary to produce a lifting beam, which is able to raise the lift. The lifting beam must be prepared in such a way that it respects correct placing of centre of gravity. At the same time it must be constructed in order to be able to carry the lift (please see table of weights).

4. **High-voltage lines**

Working near high-voltage lines is prohibited. When working near un-insulated low-voltage lines, do not go closer than 15 m to the live lines.

In general, the national safety standards for work platforms apply.

5. **Safety belt**

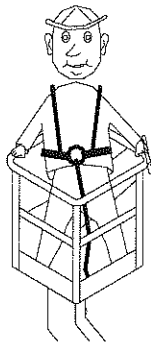

The lift is prepared for use of safety belt.  
When using a safety belt, fasten this to  
the basket.

6. **Faults**

If faults occur in the control system the lift may be switched off by means of one of the red emergency switches. On erroneous activation of the emergency switch it is possible to switch it off by turning the switch.

**7. Further precautions**

A daily functional test must be made on the lift. (cf. page 34, Maintenance).

The user should acquaint himself thoroughly with all functions and familiarize himself with:

- emergency stop
- emergency lowering valves
- manual operation of turntable, telescopic boom and basket levelling
- rotation stop
- lowering at too low voltage

The user should also react to suddenly arisen noise. If there is reason to believe that there is initial defects, then contact a service workshop.

**8. After use**

When lift operation is finished the lift must be secured against being used by unauthorized persons. The key reverser (2) is switched off and the keys are removed.



**9. Remote control**

**a. Radio transmitter**

The receiver of the wireless remote control is placed on the left hand side of the lift. The battery charger is placed under the cover at the main switch. Battery charging and receiver function are described in the operation manual for "remote control system BMS GA610", sent with the lift.

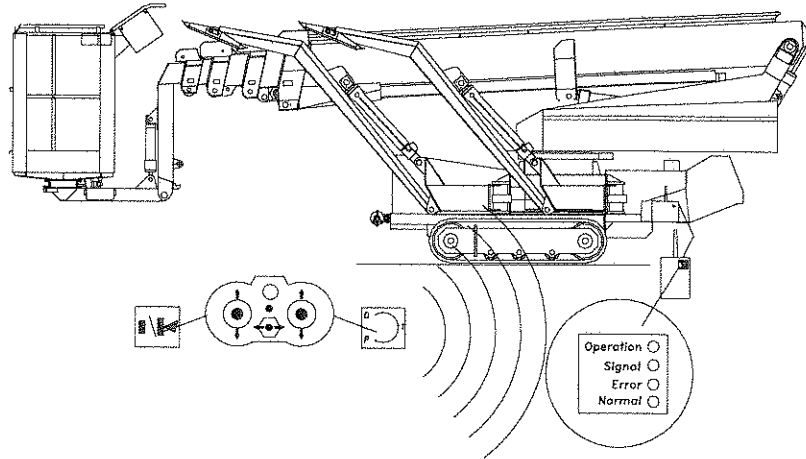

**b. Emergency drive operation**

If the control box fails, it is possible to operate the lift by means of emergency drive operation. The box for lift manoeuvring is placed under the cover on the left hand side. To activate "emergency drive operation" place key reverser, placed under the cover on the rear side of the lift, in position (1).

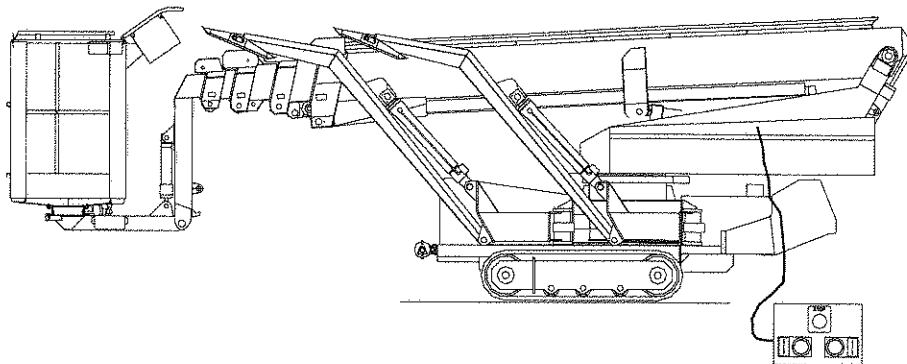

0=Radio/wired remote control  
1=Emergency operation

**c. Emergency drive operation - lifts with wired remote control**

To operate with the emergency drive box it may be necessary to insert the adapter in the plug for the remote control. The adapter is placed under the cover in the left side.

## MAINTENANCE

### 1. General

Always carry out check and repair when needed. Make complete overhaul after 500 working hours - however, always at least once a year and always after having had an accident. Every time you have to write down what has been made, please see service check report in the back of this manual. Either OMME, a company approved by OMME or a company which is competent must make the complete overhaul. In case of more comprehensive repairs, contact your importer/dealer to have the lift thoroughly tested. Warranty: OMME provides a 1-year warranty - however max. 500 working hours.

#### 1.1 Airless cleaning

Any use of a high-pressure cleaner must be carried out with consideration. Electrical control boxes and electrical components do not stand cleaning with a direct jet. Cover the charger to avoid water penetration. Then lubricate the lift thoroughly.

#### 1.2 Safety during repair and maintenance

If it is necessary to operate with a lifted telescopic boom during repair or maintenance, the mounted cylinder stop must be used, see sketch.

The lock shafts and the security splits must be mounted during operation.

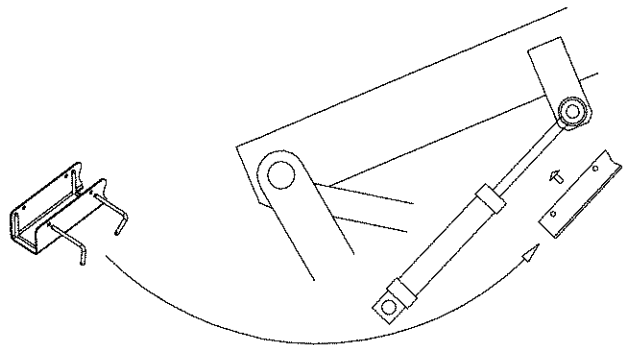

## 2. Maintenance and test

### 2.1 Daily

#### 2.1.1 Test of safety devices

**Take care!** At defective switches unintended movements may occur, which cause squeeze danger. All D, E, S and VA numbers refer to the electro-diagram.

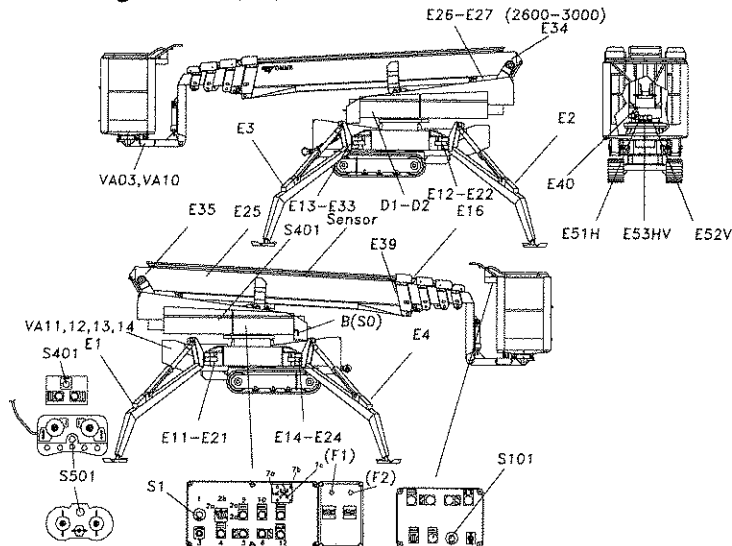

Test limit switch E16. When E16 is activated, the lift must not be able to operate (chain rupture switch).

Test electric switch "SENSOR" (load moment control). When one of the "SENSOR" switches is activated, the lift must not be able to work.

The easiest way to test the electric "SENSOR" switch is to telescope the boom outwards, until the switch interrupts the movement.

Test limit switch D1. When D1 is activated, rotation to the right must not be possible.

Test limit switch D2. When D2 is activated, rotation to the left must not be possible.

Test limit switches E1, E2, E3 and E4. If the stabilizers are not completely lowered, all lift boom movements must be interrupted. The red indicators (7b) will come on.

Test limit switches E21, E22, E23 and E24. If the pawls at the stabilizers are not engaged and if the switch is not unloaded, lift boom movements must be interrupted. The red indicators (7c) will come on.

Test limit switches E11, E12, E13 and E14. - The switches E11, E12, E13 and E14 work together with E21, E22, E23 and E24. It must only be possible to move the lift boom in the chosen working area (see page 19). At reduced working area it will only be possible to raise the lift boom 75°.

Test limit switch E35. Activate limit switch E35. It must not be possible to raise the lift boom. E35 stops the lift boom at 75° - "reduced working area".

Test limit switches E51H, E52V and E53HV. Place the lift with reduced working area, right. Activate limit switch E52V. Rotation to the left must not be possible (activate operation handle to the left). Activate E53HV. Rotation to the right must not be possible (activate operation handle to the right).

Place the lift with reduced working area, left. Activate limit switch E51H. Rotation to the right must not be possible (activate operation handle to the right). Activate E53HV. Rotation to the left must not be possible (activate operation handle to the left).

Test limit switches E25 and E34. If E25 is loaded, limit switch E34 is out of operation and lifting speed will be normal. When E25 is unloaded, lifting speed and rotation movement must be reduced. When the lift boom is more than 60°, limit switch E34 will be loaded and lifting speed will be further reduced.

**Note!** Switch E34 is only fitted on type 2600 R and 3000 R.

Test limit switch E27. When E27 is activated, operation of the stabilizers must not be possible.

Test limit switch E26. When E26 is activated, activation of the lifting cylinder must not be possible, when key reverser (2) is placed in position "lift operation" (2c).

Test limit switch E39. When E39 is activated, operation of the stabilizers must not be possible.

Test limit switch E40. When E40 is activated, all undercarriage functions must be interrupted.

Test emergency stops S1, S101, S401 and S501. Activate emergency stop in the basket (S101). All movements must now be interrupted. De-activate emergency stop in the basket. Then activate emergency stop at grand controls (S1). All movements must now be interrupted. Activate emergency stop on the mobile remote control (S501). All movements must now be interrupted. When equipped with wireless remote control, only operation of tracks will be interrupted. Activate emergency stop on the emergency drive control box (S401). (Remember! The key reverser must be placed in position 1, see page 33). All movements must now be interrupted.

### 2.1.2 Control of battery

Check the batteries according to the instructions for "Maintenance of battery" on page 48.

Check battery liquid level. Refill, if necessary, with distilled water. Battery charge condition must be checked at the beginning of each working day.

Turn on the charger with the delivered extension cable. Read on the charger how much the battery charger has been charged (see page 49).

Nightly battery charge is recommended. The battery charger is fully automatic, so it switches to additional charging, when charging has been completed. Furthermore, it is possible to charge the battery during operation.

### 2.1.3 Check of oil level

Check oil level. If necessary replenish with hydraulic oil - only fill up to the upper mark.

Standard oil, type: **Fuchs Plantolube Polar 22 S-bio**.

The lift can be supplied with a special oil type. Always check the label on tank before replenishment.

Always use the replenished oil type or an equivalent one.

In case of doubt, contact your dealer.

**Warning!** If bio-hydraulic oil is used, this is not directly miscible with all other bio-hydraulic oil types.

**NOTE!** When checking and refilling hydraulic oil the lift must be in transport position, (see sketch on page 47).

### 2.1.4 Lubrication

See lubrication points on page 47.

### 2.1.5 Check electric cables/wires

Check all accessible electric cables and - wires for eventual damages.

## 2.2 Weekly

2.2.1 Check all hydraulic screw-joints optically.

## 2.3 Half-yearly (first time after 30 working hours)

### 2.3.1 Check load moment control (inspection every six months)

- Turn the lift boom 90° in proportion to the undercarriage. Bring the boom into horizontal position ( $\pm 1^\circ$ ).
- The ambient temperature must be 15-20°.
- Place 80 kg in the basket.
- Open the electric operation box in the tower. When the lid is open, you have the overview of the electrical controlling of the load moment control. They are placed on the left side of the cover. 3 light-emitting diodes, green, red and yellow are placed on each front of the platinum. As long as the yellow light-emitting diodes are on, they are indicating that outwards telescoping and raising of the boom are allowed. When these are turned off, the maximum outreach is reached.
- Retract the boom in full. From this position the telescopic boom is driven to the outer position, until the load moment control interrupts the movement (the yellow light-emitting diodes are turned off). The distance must be (\*) m at maximum with 80 kg in the basket, measured from the centre of the turntable to the centre of the basket.

1750 R	(*) 9.40 m
1950 R	(*) 10.70 m
2200 R	(*) 11.20 m
2600 R	(*) 11.60 m
3000 R	(*) 11.30 m

- Adjusting of the load moment control must never be carried out in direct sunlight. The best condition for adjusting is when the lift has been staying in the shade and the moment system has reached a uniform temperature.
- If the distance is not correct, the system must be adjusted.

### 2.3.2 Adjusting

- Demount the guard from the rear part of the lift boom.
- With 80 kg in the basket retract telescope in full. From this position the boom is driven to outer position = (\*) m. If the movement is interrupted, before the outer position is reached, it is necessary to adjust the adjustment screw at the sensor. Less distance to the sensor gives shorter outreach, and more distance gives longer outreach.

1750 R	(*) 9.40 m
1950 R	(*) 10.70 m
2200 R	(*) 11.20 m
2600 R	(*) 11.60 m
3000 R	(*) 11.30 m

This is to be carried out at both switches - they are connected to each one unit.

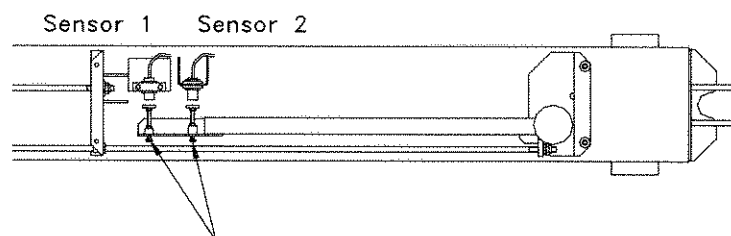

- Make the adjustments according to the above sketch.
- The correct adjustment is achieved, when the boom is (\*) m measured from the centre of the turntable to the centre of the basket, and when the yellow light-emitting diodes both are turned off.

1750 R	(*) 9.40 m
1950 R	(*) 10.70 m
2200 R	(*) 11.20 m
2600 R	(*) 11.60 m
3000 R	(*) 11.30 m

- The testing is carried out from a fully retracted telescoped boom to the outer working area. Repeat this three times and make sure that the adjustment is correct.
- Adjustment is now finished and the guard is replaced. Mount the guard in such a way, that the circular holes turn against the centre of the boom.

### 2.3.3 Control of hydraulic stabilizers

Lower the stabilizers, so that the tracks are clear of ground.

Each of the piston rods of the stabilizer cylinders is marked with a thin marker in an exact measured distance from the stripper (e.g. 50 mm). Then the lift must stay untouched for at least 30 min. If the distance to the mark has been smaller contact your supplier.

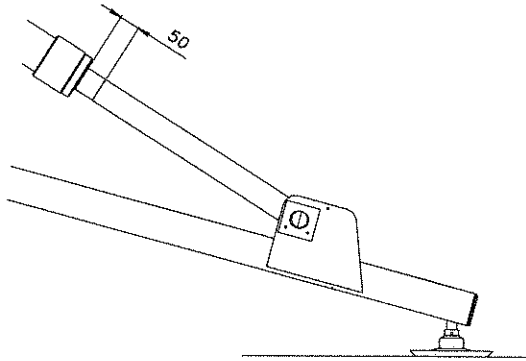

### 2.3.4 Check and lubrication of stabilizer interlocks:

Lower the stabilizers. Stop just before they touch the ground. Now raise the stabilizers manually - you must recognize stabilizer gap. The stabilizers turn slightly around the axle at undercarriage. If this is not the case, it must be repaired, as the result may be that the stabilizer interlocks does not work satisfactory. Place the lift on the stabilizers, demount guards and check the arrangement visually. The springs must be tightened and the axle A must be placed against lock edge. Check distance at switch and screw. If everything seems OK, then lubricate spring with oil. **REMEMBER TO REMOUNT GUARDS.** Rusty springs must be replaced by a new spring bundle. We recommend that the spring packets are exchanged every fifth year and that the springs are lubricated every six months.

#### Adjusting of stabilizer interlocks:

The lift is placed on stabilizers, tracks are free of ground - axle A is placed against lock edge. Tighten spring by means of Allen key, until the springs are totally squeezed together, however not so much, that axle A does not touch the lock edge. Adjust at switch - there must be approx. 1 to 1.5 mm space.

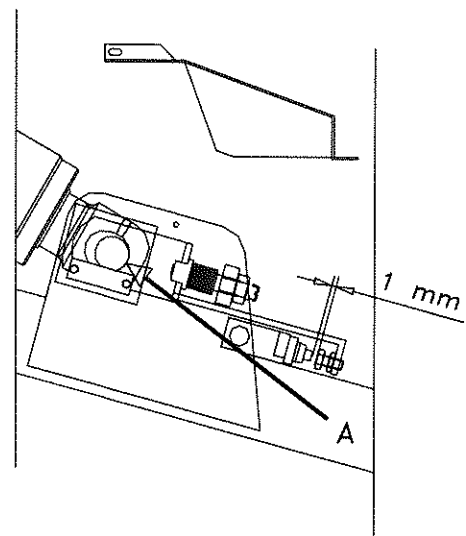



### 2.3.5 Check of boom system

The boom system is constructed to tolerate hundreds of working hours, however intensive use and working with abrasive particles may increase wear.

We therefore recommend the below half-yearly check of boom wear.

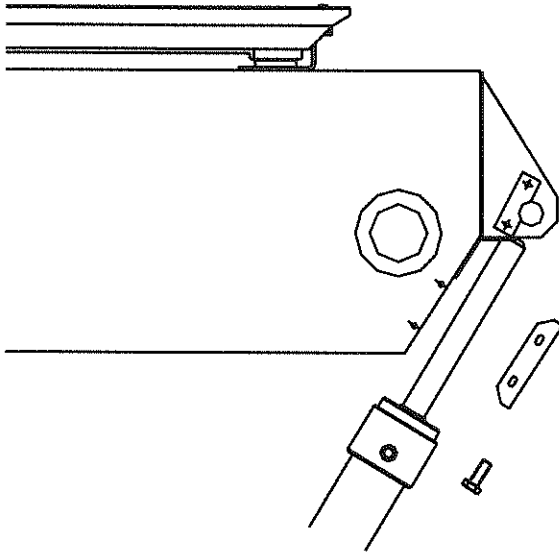

Telescopic boom(s) must be fully retracted - transport position.  
Demount rear cover plate on boom.

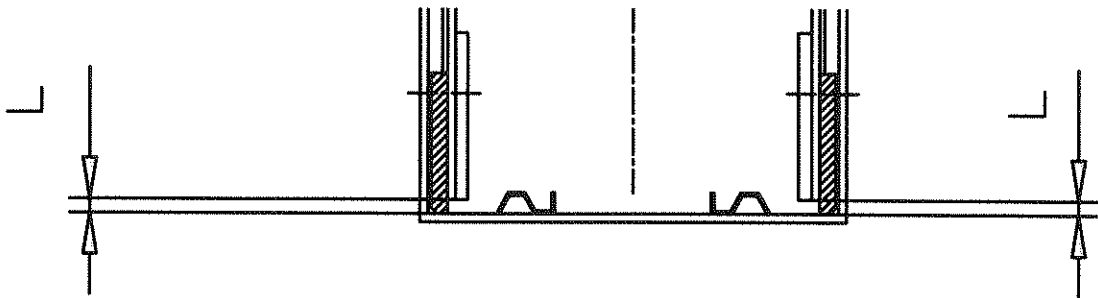

Measure distance from bottom of boom to under side of side plate of the rear side of boom (see sketch). For the measuring it is of advantage to use search sheets.

The distance must never be smaller than mentioned below:

**1750/1950/2200 RBD:        2 mm (5 mm at new wear plate)**

**2600/3000 RBD:            4 mm (7 mm at new wear plate)**

If you move below the distance, it is necessary to exchange wear plates and to check booms.

### 2.3.6 Guidelines for disassembling booms

If one of the following points is noted, it is advisable to disassemble the booms completely or partly.

- a. If the booms contain larger quantities of splints or other particles.
- b. If the booms and the telescopic connections make too much noise and this cannot be removed at lubrication.
- c. If defects on the booms or the telescopic connections are optically observed.
- d. If oil or cable routings are defective and it is not possible to draw new ones through the laying.
- e. If the wearing blocks in the rear end of boom 1 are worn to below the permissible. Half-yearly inspection is recommended. See point 2.3.5.
- f. If the chains in the telescopic connection have been prolonged more than permissible. See point 2.3.7.
- g. If it is suspected that there is a defect in the booms or in the telescopic routing, which cannot be controlled, without having to disassemble the booms completely or partly.
- h. We recommend that the booms are thoroughly inspected after 5 years or 2500 working hours.

When disassembling the booms, OMME recommends that the turning rolls in the cable routing are exchanged with new rolls from OMME.

### 2.3.7 Checking chains

Chains are checked at annual inspection. Chains must be exchanged, if the prolonging exceeds a 3% prolonging. The chain must also be exchanged, if rusting leads to the link not being able to move in proportion to each other. The chain lengths, mentioned below, are inclusive manufacturing tolerances for new chains.

Check: once a year

1/2" - 2x2

1/2" - 4x4

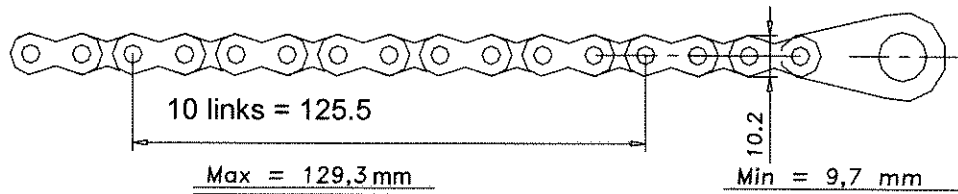

5/8" - 6x6

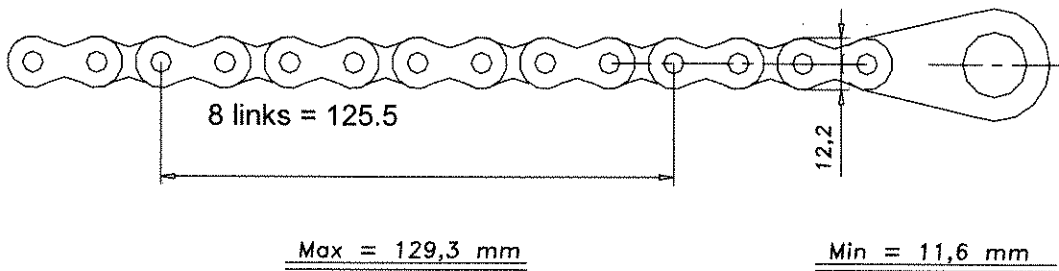

3/4" - 8x8

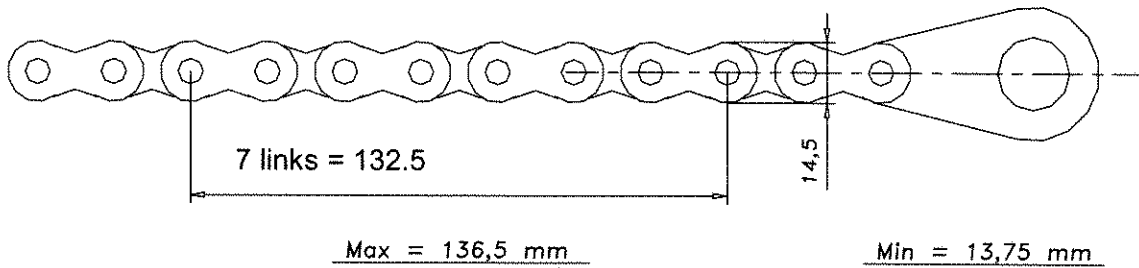

Max. permissible wear on chain length = 3%

Max. permissible wear on chain link width = 5%

## 2.4 Yearly (first time after 30 working hours)

### 2.4.1 Control of turntable

Your lift is mounted with a precision turntable, which makes it possible to transfer big forces to all directions from the pivot point of the lift.

It is important that the turntable is frequently checked visually and at least once a year (first time after three months) the pre-stressed bolts of the turntable must be controlled with a torque wrench. Tension M12 = 128 Nm, M16 = 210 Nm. Check the turntable connections both from the side of the tower as well as from the bottom part of the undercarriage, where it is necessary to turn the tower in order that control of all bolts is possible.

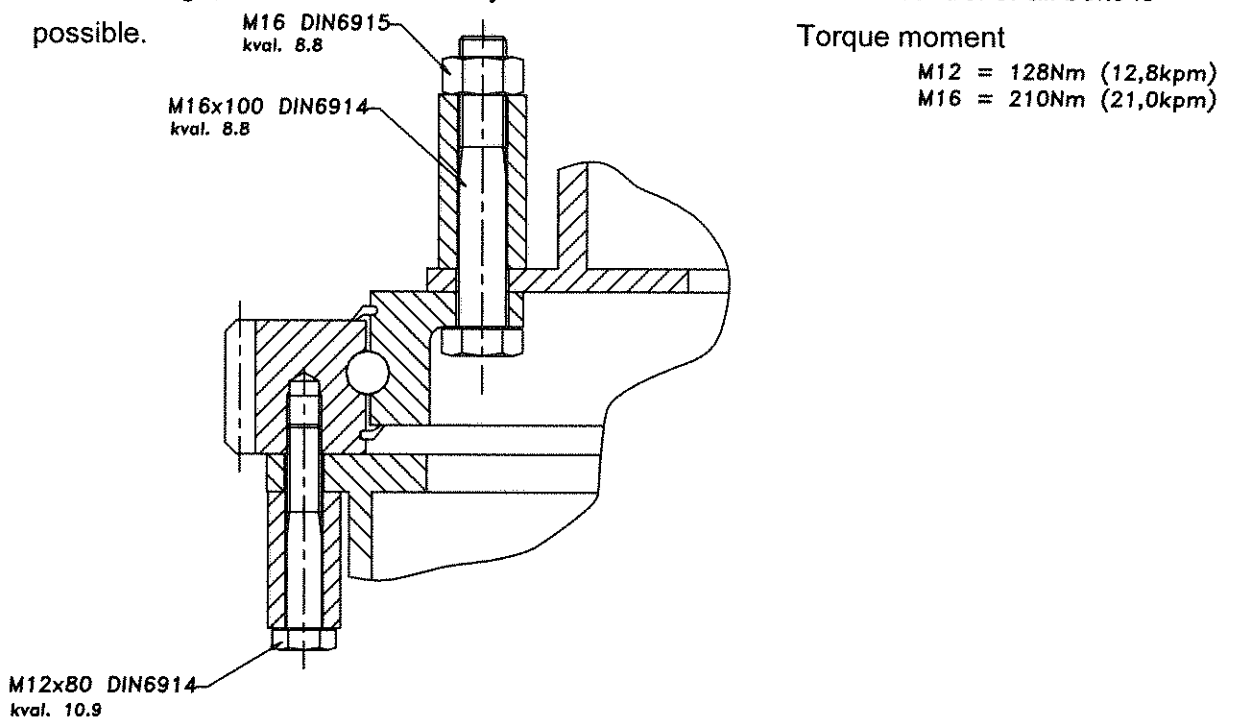

- Initial tension must be crosswise and with intervals of 180° (progressive).
- Final tension must be 128 Nm for M12 and 210 Nm for M16 bolts.
- Flat washers with a tension higher than 700 N/mm<sup>2</sup> must be used.
- Lock washers must not be used at the bolts of the turntable.

**NB!** Mechanical work in the turntable connections must be made by an OMME service shop or a shop recommended by OMME.

### 2.4.2 Hydraulic screw joints

Adjust all hydraulic screw-joints, bolts and screws.



**Check points**

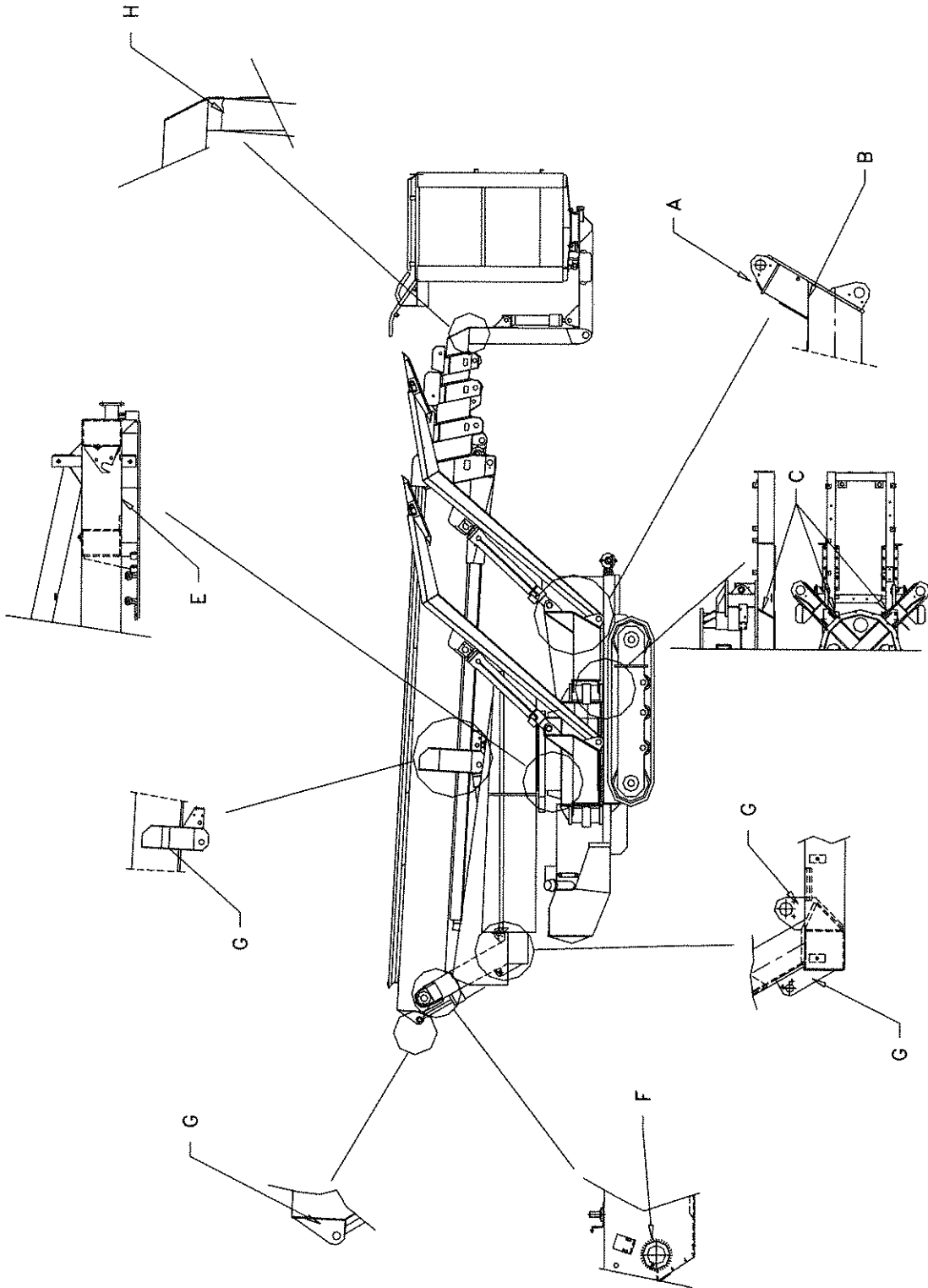

2.4.3 Check rotating and moving parts, bolted joints and welds for formation cracks

**Undercarriage**

- Stabilizer brackets.  
(Construction from stabilizers to square profile)  
Check welds for formation cracks (A).
  
- Attachment of square profiles to undercarriage profile.  
Check welds for formation cracks (B).
  
- Side members for diesel engine and crawlers.  
Check welds for formation cracks and side members for cracks (C).

**Cylinders**

- Cylinder attachments.  
Check welds for formation cracks (G).

**Tower**

- Turntable-/pivot connection.  
Check welds for formation cracks (E).

**Boom system**

- Centre of rotation of booms.  
Check welds for formation cracks (F).
  
- Knee point on smallest boom.  
Check welds for formation cracks and for folding in profile (collision) (H).

### 3. Lubrication points

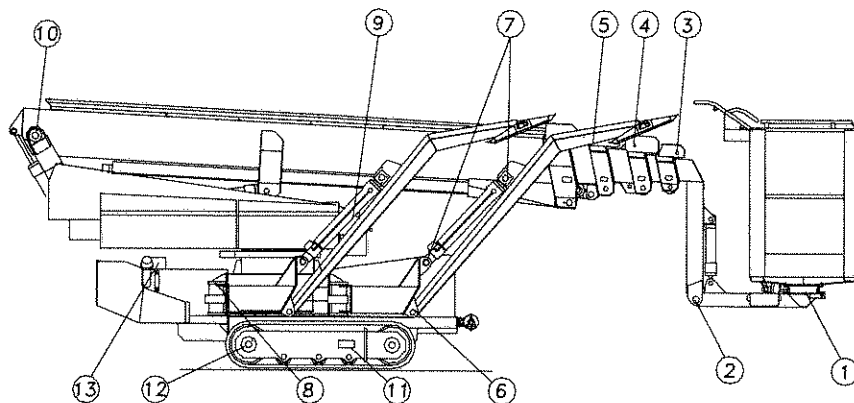

Pos.	Lubrication points	Number of lub. points	Lubricants	M
1	Turntable, basket	2	Grease	x
2	Lever arm	1	Grease	x
3	Chain axle, boom 3	2	Grease	x
4	Chain axle, boom 2	2	Grease	x
5	Chain axle, boom 1	2	Grease	x
6	Stabilizer	4	Grease	x
7	Stabilizer cylinder	8	Grease	x
8	Swivel arms for stabilizers	4	Grease	x
9	#) Turntable	2	Grease	x
10	Axle, tower/boom	1	Grease	x
11	Tightening of tracks, special nipple, forced lubrication to 150 bar **)	2	Grease	
12	Check oil level in gear			x
13	*) Oil filter (exchange)	Number 1	Type F101-600E	

M = Monthly

\*\*)) When the tracks need tightening.

**Note!** On lifts with movable jib boom no extra lubrication points are added.

#) Lubrication of turntable: Place the lift on the stabilizers. Lubricate the two lubrication points. Now rotate the lift one round. Lubricate the two lubrication points again. Now rotate the lift back to starting point.

When refilling oil on the pumping station for the jib boom, the guard over the pumping station must be demounted.

The mentioned lubrication intervals are based on normal operation. For intensive operation the lubrication intervals must be shortened.

In case of a longer period of standstill the detached piston rods (e.g. levelling rods) should be greased.

\*) Change oil and oil filter after 500 working hours, however always at least once a year.

Oil type: See point 2.1.3 or label on tank.

**Note!** Airless cleaning always lubricate the lift to remove penetrated water, if any.

Concerning point 11 and 12: See the manufacturer-manual for tracks.



4. **Maintenance of battery**

Charging the battery

1. **Charge**

- Connect 230 V mains voltage.
- Charger in open circuit - ready indicator lights up.

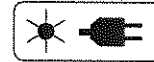

2. **Control panel**

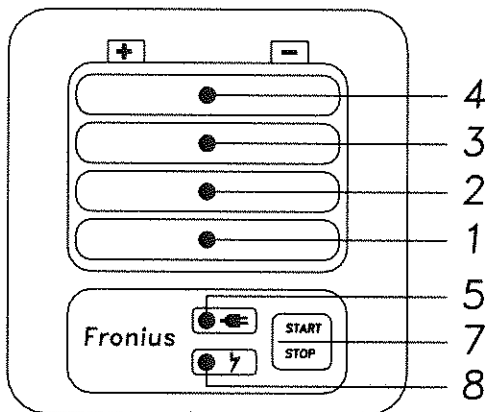

No.	Function
1	Charge level indicator 25%
2	Charge level indicator 50%
3	Charge level indicator 75%
4	Charge level indicator 100%
5	Ready indicator
6	(-)
7	Start/stop and setup button - Is placed in position Start from OMME. The charger starts, when 230 V mains voltage is connected. For description of the setup function please see the enclosed instruction for battery-charger: The charger is adjusted from factory, modified to this lift. Therefore do not use the setup function.
8	Error indicator

**Plugging in options:** **NOTE!** Risk of damage to charger and accessories. Only plug in options and system add-ons when the mains plug is unplugged and the charging cable is disconnected from the battery.

### 3. Charging procedure

- a. Charging begins automatically after approx. 2 seconds.
- b. A set of four LEDs show the battery's charge level.

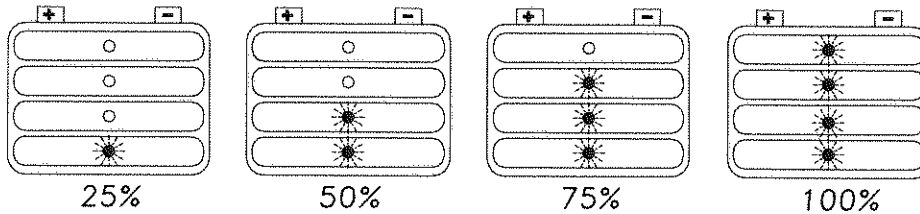

- c. Conservation charging: Once the battery is fully charged, the charger automatically switches to conservation charging to prevent battery self-discharge. The battery can remain connected to the charger for any length of time.

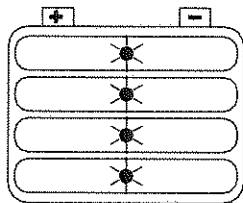

### 4. Charging errors

#### Operating indicator on, fault indicator flashing, charge level indicator 1/2/3/4 flashing.

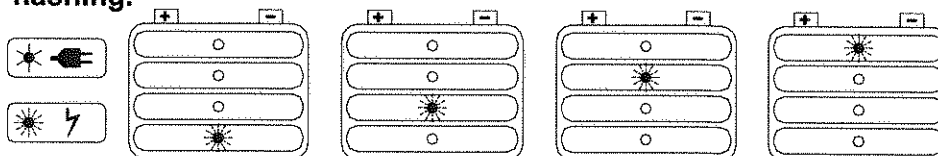

Cause: Timeout in the corresponding charging phase or battery capacity too high.

Remedy: Select correct characteristic type according to the enclosed characteristic data sheet and charge again.

Cause: Battery faulty (cell short circuit, heavy sulphation).

Remedy: Check battery and replace if necessary.

Cause: Optional external temperature sensor has tripped due to over or undertemperature.

Remedy: Allow battery to cool or charge battery in a more suitable area.

#### Charger switches off during charging

Cause: Ambient temperature too high. Overtemperature protection active.

Remedy: Allow charger to cool down. Charging will recommence automatically once the charger has cooled sufficiently.

If not, have it checked by a workshop.

### Tending the battery

#### **Keep terminals and terminal connections clean.**

Dirty and loose terminal connections prevent optimum charging and reduce battery output.

#### **Plates must be covered with acid**

Check acid level and note that if the plates are not completely covered with acid, they will be destroyed. Too much acid in the cells will cause the acid to boil over, when charging. Make sure that only absolutely clean, distilled or demineralised water is used as refill. (Never refill with acid or utility water).

#### **NOTE! NOTE!**

**During charging oxyhydrogen gas is generated, so open fire, sparks and embers must NOT be near the battery when charging.**

### Checks and maintenance

1. Check acid level and refill with electrolyte if necessary.
2. Check specific gravity with an acidometer, it must be 1.26 to 1.28, when the battery is charged. If the specific gravity is less than 1.26 to 1.28, the battery must be recharged.
3. If the battery has been soiled, it is cleaned in ample hot water in order to remove the dirt and avoid sneak current. A battery which is kept clean and charged lasts the longest.
4. Batteries which are not in use must be charged regularly, and they must be stored in a dry place.

#### **NOTE! NOTE!**

**If the battery is discharged to specific gravities less than 1.14 to 1.16, its life is reduced considerably.**

5. During charging electrolyte temperature must not exceed 40 degree C, as that would have a destructive effect on the accumulator.

## 5. Maintenance of internal-combustion engine KUBOTA D722-E

To achieve greater efficiency, a more economic operation and a longer life time we recommend that you read the enclosed **KUBOTA-MANUAL** thoroughly and make sure, that the engine is operated and maintained correctly. If the engine is operated and maintained as prescribed, you will learn that you have made a good investment in the long run.

As the engine can be operated from the basket, we have made some changes regarding operation compared with the **KUBOTA-MANUAL** prescriptions.

1. Preheating of the engine is carried out automatically. Having pushed down the START-button, the engine preheats for about 4 sec., before the engine starts.
2. Check of oil pressure: There is no oil lamp, which will shine, if pressure is no longer established. Having no pressure, the engine stops automatically.
3. Check of water temperature: There is no thermometer or lamp, which indicates if the engine is superheated. The engine will stop automatically, if the water temperature becomes too high. **Note!** The water temperature in the engine always rises, just after the engine has stopped. This is the reason why the engine may not start, shortly after it has stopped, e.g. if the air temperature is very high.

### Regular maintenance of KUBOTA D722-E

1. Check oil, water and fuel quantity - daily.
2. Check air filter and fuel filter frequently for impurities. Clean as prescribed in the **KUBOTA-MANUAL**.
3. Change oil and oil filter according to the intervals prescribed in the **KUBOTA-MANUAL** - however, the first time after 50 working hours. Always use an oil, which corresponds to the quality prescribed by **KUBOTA**. The viscosity must correspond to the season. This engine has an oil pan depth of 121 mm, which is influencing the oil quantity and the frequency of the change of oil filter.
4. Check anti-freeze mixture before winter time - and during the whole winter period, if water is frequently poured on the radiator.

### WARNING!

#### To avoid damage on persons:

NEVER remove the radiator cover, when the engine is running, or after it has stopped, and the engine is still hot. Otherwise you may risk, that the boiling water will bubble up and scald persons standing nearby. Do not remove the radiator cover until after at least 10 minutes, that is when the engine is cooled.

## **TROUBLE-SHOOTING**

### **1. General**

- a. Is main switch (B) (S0) activated?
- b. Are the emergency stops (S1, S101, S401 and S501) active?
- c. Is there power on the battery?
- d. Is the basket load higher than permitted?
- e. Are the fuses ok? (160 A main fuse and 10 A control fuse).
- f. Is the oil level in tank ok?

### **2. Stabilizers cannot be lowered**

- a. Is the position of the key reverser (2) correct?

### **3. The boom cannot be raised**

- a. Is the handle (H) on the tower front placed in lowest position? (Must be placed in upper position).
- b. Is the position of the key reverser (2) correct?
- c. If necessary, adjust the potentiometer (3) to a higher level.
- d. Check voltage, if necessary, press in and release emergency stop.
- e. Is the lift placed correctly ? Check the indicators for placing control. The 8 red indicators (7b) and (7c) must now be switched off. The green indicator (7a) must come on.

**4. The boom cannot be lowered**

- a. Has the lift reached its max. outreach, so that the load moment control valve (SENSOR) is interrupted?
- b. Is the position of the key reverser (2) correct?
- c. Check voltage, if necessary, press in and release emergency stop.

**5. The boom cannot be telescoped outwards**

- a. Are there any hindrances for the lift?
- b. Has the lift reached its max. outreach, so that the load moment control valve (SENSOR) is interrupted?
- c. Is the position of the key reverser (2) correct?
- d. Check voltage, if necessary, press in and release emergency stop.
- e. Is chain rupture switch E16 activated?

**6. The boom cannot be telescoped inwards**

- a. Are there any hindrances for the lift?
- b. Is the position of the key reverser (2) correct?
- c. Check voltage, if necessary, press in and release emergency stop.
- d. Is chain rupture switch E16 activated?

**7. The lift cannot turn to the right or to the left**

- a. Are the stabilizers turned out to maximum position ?
- b. Are there any hindrances for the lift?
- c. Are D1 and D2 active ? Is right ok, but left not. Turn at least 90° to the right and then try to the left again (The lift had reached its outer position).

**8. Too short operating time on the battery**

Check the battery according to "Maintenance of battery", page 48.

**9. No charge indicator deflection**

Check the following:

- a. Is the charger connected to 230 V?
- b. Is the connection to the battery ok?

**10. Indication lights for placing do not function appropriately**

- a. The red indicators (7b) and (7c) do not come on.  
Is key reverser (2) placed in position stabilizers (2a)?  
Is emergency stop (S1), (S101), (S401) or (S501) active?
- b. The red indicators (7b) continue to shine  
Are E1, E2, E3 and E4 active?
- c. The red indicators (7c) continue to shine.  
Are pawls not engaged correctly?
- d. The green indicator (7a) does not come on?  
Are E16 and (SENSOR) activated?  
Is the basket more than  $\pm 10^\circ$  oblique?  
Is emergency stop (S1), (S101), (S401) or (S501) active?  
Is the power on the battery ok?

11. If you have not found the error going through the above instructions, please contact your dealer/importer to make eventual arrangement for a service visit.

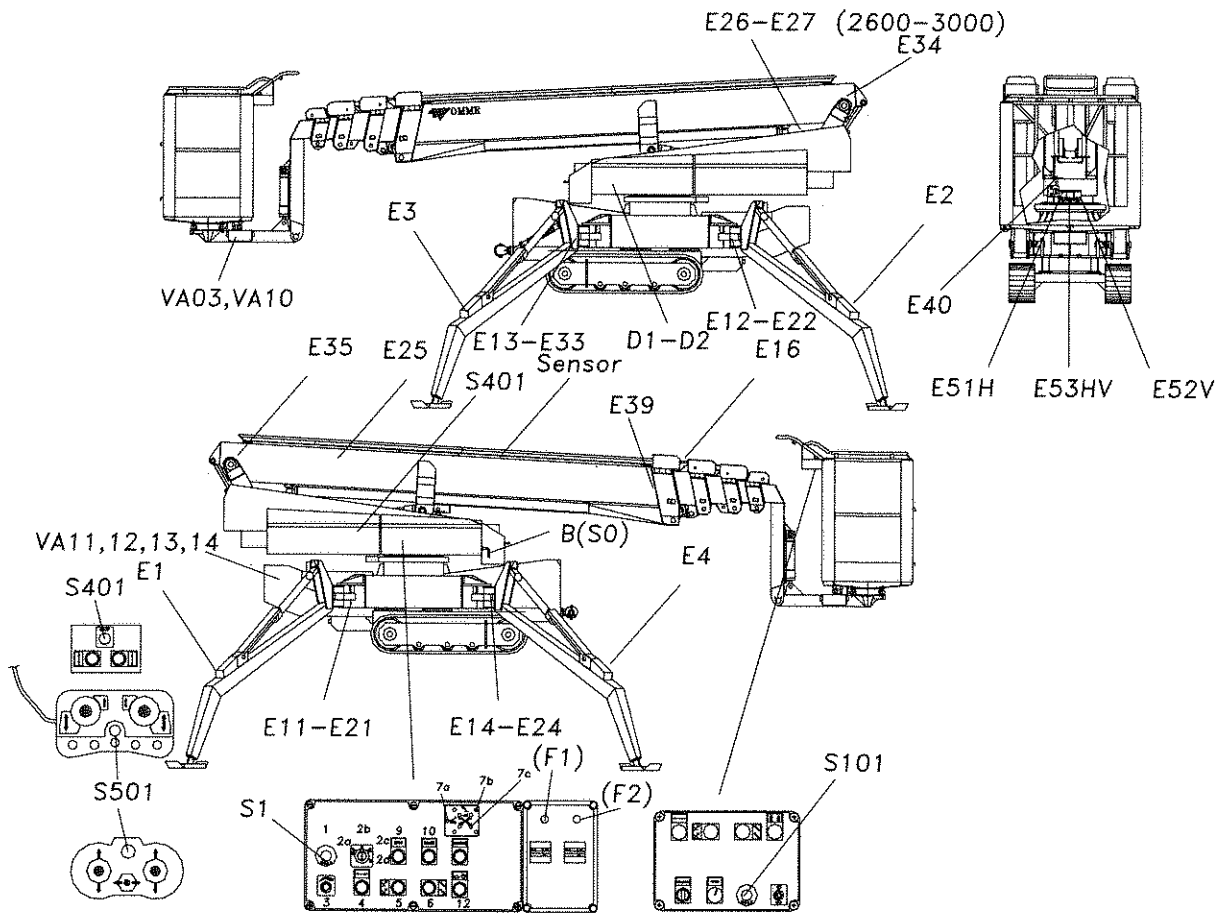



**ORDER NUMBERS**









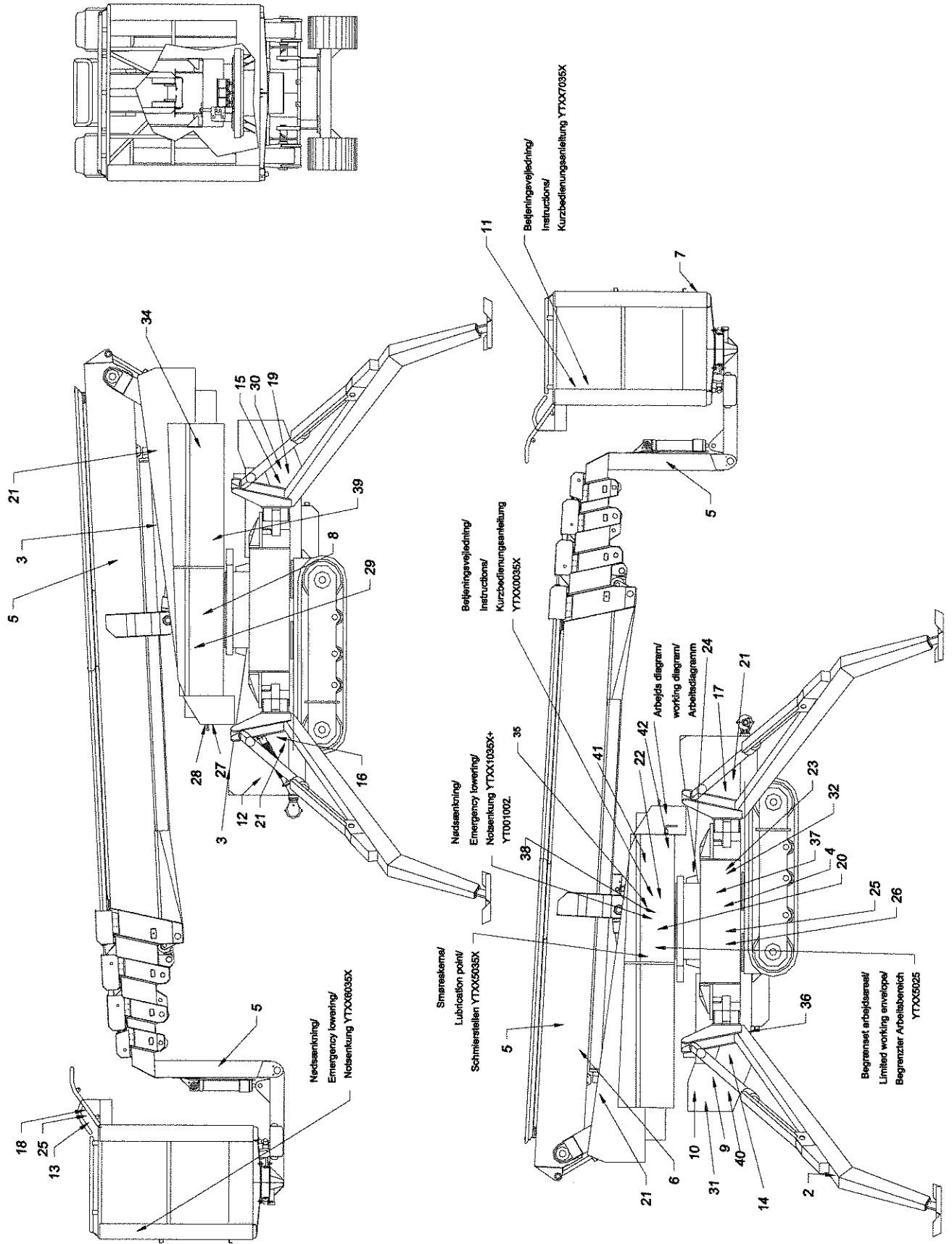

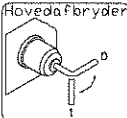
**FOR**

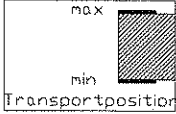
**DECALS**

**OMME RBD(J) -  
on crawlers**

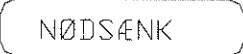
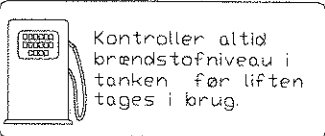
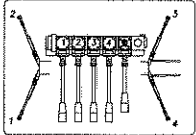
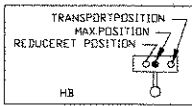
*Always state lift serial No. and requested language!*

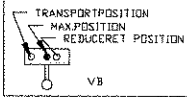
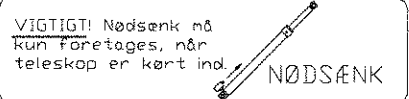
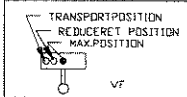

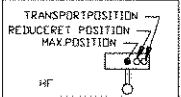
1		YTXX5005	8		YT005008
2	<p>Max. 14,5 kN</p> <p>Type 1750 PLL: YTSF0013</p> <p>Max. 16,5 kN</p> <p>Type 1950 ULL: YTSF0016</p> <p>Max. 18,0 kN</p> <p>Type 2200 SLL: YTSF0011</p> <p>Max. 23,5 kN</p> <p>Type 2600 TLL: YTSF0015</p> <p>Max. 25,0 kN</p> <p>Type 3000 VLL: YTSF0014</p>		9		YT005013
			10		YT006004
			11		YTXX5003
			12		YT000012
3		YTXX1102	13		YTXX5015
4		YT004002	14		YTXX5037
5		XXXXXXXXXX	15		YTXX5039
6		YTXX1100	16		YTXX5036
7	MAX.200KG.  +40KG. 09650435		17		YTXX5038

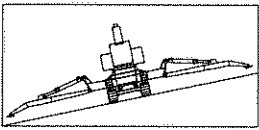
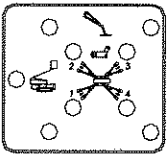
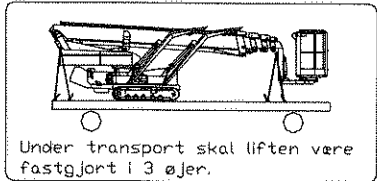
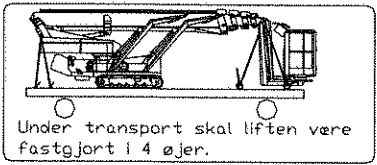
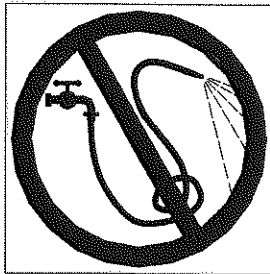
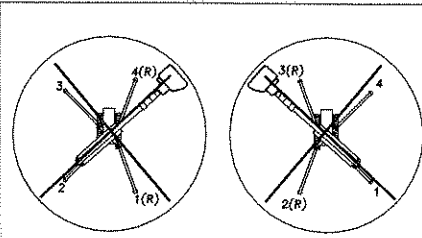

18	MAX.230V/10A	YT006006	28	Lift drift	YTXX5024
19	230 volt ~	09650260	29	Adaptor stik	YTXX1911
20		YTXX6021	30	VIGTIG! Hvis fjernbetjenings-enheden beskadiges, afbrydes alle funktioner. Dog kan det løse adaptorstik, placeres ved nød-betjeningsboksen. Adaptorstikket monteres og alle funktioner genetableres.	YTXX1910
	For at undgå væltning ved kørsel på skråning. Brug da støttebenene som sikkerhed!				
21	Løfte øje	YTXX5040	31	ADVARSEL! Den påfyldte bio-hydraulikolie er ikke umiddelbart blandbar med alle øvrige bio-hydraulikolier.	YTXX2001
22		YT000014	32		YTXX5041
23	ØBS! Hæv og sænk altid støttebenene samtidig.	YTXX5027		Under transport skal liften være fastgjort i 3 øjer.	
24	T r a n s p o r t  P o s i t i o n	YTXX5023		Jibr 	YTXX5046
				Under transport skal liften være fastgjort i 4 øjer.	
25	Motoren starter først når forvarmningen er afsluttet. Vent ca. 4 sek.	YTXX5014	33	0 Radio/Kabel	YTXX8003
				1 Nødkørsel.	
26	Ved arbejde med dieselmotor er høreværn påbudt	YTXX5028	34		YT005043
27	Transport position	YTXX5022	35		YTXX1009
				BEMÆRK! KUN VED NØDSÆNK. Ved reduceret benstilling må liften aldrig drejes ind i det reducerede område. Liften vil da vælte.	



36

YT006007

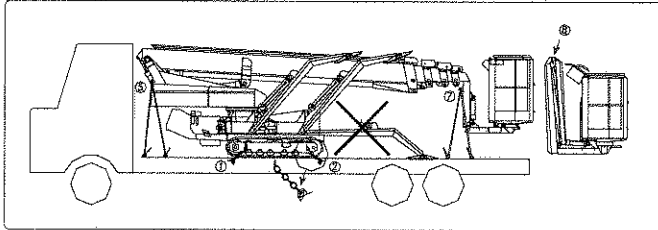

40

YTXX8005

Bag skærm.  
10A sikring

37

YT005042

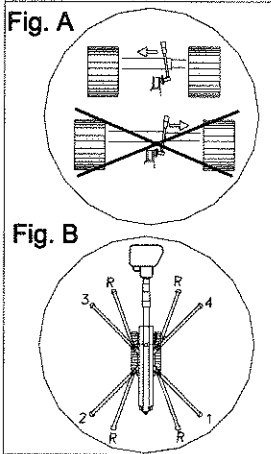

41

YTXX8004

**Betjeningsvejledning støtdebensautomatik.**

1. Støtdebensautomatik betjenes med en drejeknap med 3 stillinger og korrekt opstilling indikeres ved at den grønne lampe lyser.
2. **Opstilling af lift:** Bevæg knappen "nedad" og hold denne aktiveret. Støtdebene bevæger sig nedad og bevægelsen stopper automatisk, når liften er opstillet korrekt og den grønne lampe lyser. Hvis liften ønskes løftet højere op kan knappen aktiveres igen og liften vil hæve sig lodret op, indtil knappen slippes eller maksimal højde er nået.
3. **Nedtagning af lift:** Bevæg knappen "opad" og hold denne aktiveret, indtil støtdebene er helt oppe eller i den ønskede position.
4. **Generelt:** Hvis automatikken under opstilling ender med at køre en eller flere af støtdebenscylindrene helt i bund - uden at liften er korrekt opstillet - anbefales det at bevæge knappen "opad" et kort øjeblik, således at den høje ende af liften sænkes lidt og derefter bevæge knappen "nedad", således at automatikken igen får mulighed for at stille liften korrekt op.

Støtdebene kan også betjenes med de manuelle hydraulikhåndtag.

Inden transport af liften, kontroller da at støtdebene er i transportstilling eller i den ønskede position ved kørsel i terræn.

38

YTXX5204

42

YTXX4107

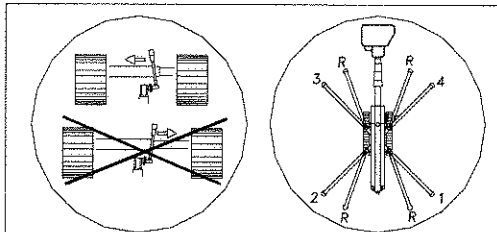

Før støtdebene sænkes, skal benene være låst fast i arbejdsposition, fig.B. Ved reduceret benopstilling skal larvebåndene være i smalleste position, fig.A. Når støtdebene sænkes og heves skal det gøres parvis, bageste(1-2) og forreste (3-4). Er liften stillet op med reduceret benopstilling (R) til højre, giv da støtteben (2og3) et ekstra tryk. Til venstre gælder det støtteben (1og4).

STØTTEBEN OK

39



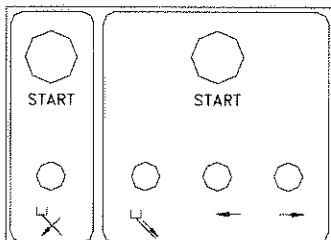







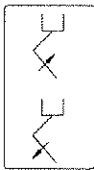
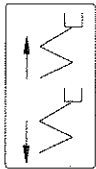

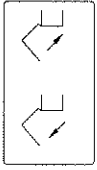
YTXX1008

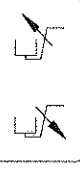
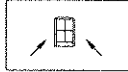
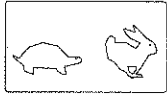
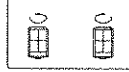

Elektrisk nødsænk: Tryk på start og aktiver den funktion som kræver nødsænk. Bemærk! Nødsænk af arm ned kan først foretages når teleskop er inde.



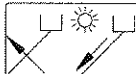
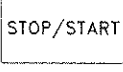

1		57000430 Drejning, højre/venstre Drehung, rechts/links Rotation, right/left	12		57000435 Underarm, op/ned Unterer Ausleger, auf/ab Lower boom, up/down
2		57000485 Saksearm, op/ned Scherenarm, auf/ab Scissor boom, up/down	13		57000400 (Knæk lifte) Teleskoparm, ud/ind Teleskopausl., aus/ein Telescopic boom, out/in
3		57000445 Arm, op/ned Ausleger, auf/ab Boom, up/down	14		57000450 3. arm, op/ned 3. ausleger, auf/ab 3rd boom, up/down
4		57000410 (Teleskop lifte) Teleskoparm, ud/ind Teleskopausl., aus/ein Telescopic boom, out/in	15		57000425 "Rotorblink" "Rotor leuchte" "Rotary light"
5		57000452 Jib arm, op/ned Beweglicher Korbarm, auf/ab Jib boom, up/down	16		57000420 Opretning af kurv Aufrichtung Korb Alignment of basket
6		57000465 Hastighed, høj/lav Geschw. hoch/niedrig Speed, high/low	17		57000405 Drejbar kurv Drehbarer Korb Turnable basket
7		57000470	18		57000415
8		57000455	19		57000475
9		57000460	20		57000530 Moment OK
10		57000462	21		57000490
11		57000480 Potentiometer			



Service check report Omme lift A/S

Order no.:	Serial no.:	Customer reference no.:
Phone no.:	Year:	Product:
Company:	Type:	
Address:	Hour meter:	
Postal code:	Town:	

CHECK LIST FOR MOBILE PERSONAL ACCESS PLATFORM

A=OK B=repair on occasion C=not OK			A	B	C	A=OK B=repair on occasion C=not OK			A	B	C
<b>1. Special safety equipment</b>			3.3 Adjustment and sealing			<b>7. Chassis, undercarriage &amp; stabilizers</b>					
1.1 Type sign			3.4 Guard			7.1 Construction (deformation, rust, cracks and breakages)					
1.2 Warning-, instruction decals and operation symbols			3.5 Hydraulic tank			7.2 Bolts, bolted joints					
1.3 Safety switches / sensors			3.6 Pump			7.3 Bearings, axles and moving links					
1.4 Light indicators			3.7 Motor			7.4 Lock pins and locking devices					
1.5 Emergency stop			3.8 Oil			7.5 Stabilizers and baseplates					
1.6 Lockable reverser			3.9 Filter			7.6 Function controls of stabilizer levelling system up and down					
1.7 Main switch			3.10 Leakages, untightnesses			7.7 Lift fittings and ball hitch					
1.8 Safety harness			3.11 Function controls, especially extreme positions			<b>8. Work stand</b>					
1.9 Emergency lowering function			3.12 Pipes, hose rupture and load over centre valves			8.1 Construction (deformation, rust, cracks/breakages)					
1.10 Spirit levels			3.13 Hydraulic safety valves			8.2 Bolts, bolted joints etc.					
1.11 Level adjustment and slope alerts			<b>4. Motor and fuel system</b>			8.3 Fastening of work stand					
1.12 Warning light indicator / flashing beacon			4.1 Fuel system, tank and filters			8.4 Gate function, movable rail					
1.13 Overload fuse/Torque			4.2 Motor and transmission			8.5 Rail, hand-, knee-, and wall bases					
1.14 Guards			<b>5. Electro- and charging system</b>			8.6 Flooring and cable routing					
1.15 Transport position automatics			5.1 Battery, battery box, battery weight & battery connections			8.7 Telescoping platforms etc.					
<b>2. Brakes, steering gear, tyres, indicators and operator controls</b>			5.2 Electro-system, wires and plugs			8.8 Anchor point for safety harness					
2.1 Brakes			<b>6. Lifting device (boom, articulated boom, scissors, chains etc.)</b>			8.9 Instructions in basket					
2.2 Wheel and wheel suspension			6.1 Construction (deformation, rust, cracks, breakages)			8.10 Labels - load (persons, load)					
2.3 Tyre wear and - pressure			6.2 Bolts and bolted joints etc.			<b>9. Other important check points</b>					
2.4 Indicators, lamps and reflexes			6.3 Bearings, axles and moving links			9.1 Load test: KG					
2.5 Signalling device, horn			6.4 Slide shoe, -block, -lists etc.			9.2 Report and journal/label					
2.6 Operating devices - symbols			6.5 Limit switches			9.3 Manual					
			6.6 Transport fittings			9.4 Maintenance instructions					
<b>3. Hydraulics</b>			6.7 Rotary system, among others turntable and functions			9.5 CE-marking 1. January 97					
3.1 Pipes, hoses and screw-joints			6.8 Chains			9.6 EC- conformity certificate					
3.2 Control valves			6.9 Speed for movements			9.7 EC-type approval					
			6.10 Function controls								

Remarks (at first fill in the number in request, e.g. 1.5):

Accepted:  Not accepted:

Date and signature: \_\_\_\_\_

\_\_\_\_\_

\_\_\_\_\_

\_\_\_\_\_

